



Design of Medicine Dispenser Vending Machine using Proteus Software

Mrs.K.ROKINI M.E., AP/BME, Ms.R.Brindhha , Mr.S.Manikandan, Ms.R.Shabari, Ms.A.Vinomathi

Excel Engineering College, Komarapalayam, Tamilnadu, India

Publication History: Received: 25.02.2026; Revised: 20.03.2026; Accepted: 25.03.2026; Published: 28.03.2026.

ABSTRACT: The rapid growth of healthcare demands efficient and automated solutions to improve medicine accessibility and reduce human dependency in dispensing systems. This paper presents the design and simulation of an automated medicine dispenser vending machine developed using Proteus Design Suite. The proposed system integrates a microcontroller-based control unit, keypad interface, display module, and motor-driven dispensing mechanism to ensure accurate and controlled delivery of prescribed medications.

The system is designed to operate based on user authentication through an ID input method, enabling secure access to pre-assigned medicines. Once authenticated, the user can select the required medicine within predefined limits, and the system dispenses the medication while simultaneously updating inventory data. The simulation environment in Proteus allows real-time testing of circuit behavior, component interaction, and system reliability without physical implementation.

The proposed design eliminates manual errors, reduces waiting time in pharmacies, and enhances patient convenience, especially in high-demand environments such as hospitals and clinics. Furthermore, the modular architecture enables easy scalability and future integration with advanced technologies such as IoT-based monitoring and cloud-based prescription management systems. The results demonstrate that the system is cost-effective, reliable, and suitable for modern healthcare automation.

KEYWORDS: Automated Medicine Dispenser, Vending Machine System, Proteus Design Suite Simulation, Microcontroller-Based Design, Healthcare Automation, Secure Drug Dispensing, Embedded Systems, Inventory Management, Smart Healthcare System, Digital Prescription Handling

I. INTRODUCTION

The advancement of healthcare technology has significantly transformed the way medical services are delivered, with automation playing a crucial role in improving efficiency and accuracy. In conventional pharmacy systems, medicine dispensing is largely dependent on manual processes, which can lead to long waiting times, human errors, and increased workload for pharmacists. These challenges highlight the need for an intelligent and automated solution that ensures safe, quick, and reliable medicine distribution.

An automated medicine dispenser vending machine is an emerging solution designed to streamline the dispensing process by integrating embedded systems and digital control mechanisms. This system enables patients to access prescribed medicines through a secure and user-friendly interface, reducing the need for direct human intervention. By incorporating authentication methods such as unique patient IDs, the system ensures that only authorized users can access specific medications, thereby enhancing safety and compliance.

In this project, the design and simulation of a medicine dispenser vending machine are carried out using Proteus Design Suite. The simulation approach allows for efficient testing of circuit design, component interaction, and system functionality before physical implementation. The proposed system includes key components such as a microcontroller, keypad input, display unit, and motor-driven dispensing mechanism, all integrated to perform automated operations.

Furthermore, the system addresses key issues in healthcare environments, including medication errors, inventory management, and patient convenience. By automating the dispensing process, the system not only reduces operational delays but also ensures accurate dosage delivery. The modular design also provides flexibility for future enhancements, such as integration with Internet of Things (IoT) technologies and centralized medical databases.



Overall, this project aims to contribute to the development of smart healthcare systems by providing a cost-effective, reliable, and scalable solution for automated medicine dispensing.

II. LITERATURE REVIEW

In recent years, the automation of medicine dispensing has gained significant attention in the healthcare industry due to the increasing need for accuracy, safety, and convenience. Shanthini et al. (2023), Patel et al. (2024), Nasir et al. (2023), Gargioni et al. (2024), and Sallam (2024–2025) have collectively contributed significant research on automated medicine dispensing and smart pharmacy vending systems in healthcare. Their studies highlight the importance of automation in reducing human errors, minimizing patient waiting time, and improving efficiency in medicine distribution. The proposed systems mainly integrate embedded systems, sensors, microcontrollers, IoT technology, and database connectivity to identify, store, and dispense medicines according to electronic prescriptions. Security features such as QR code scanning, fingerprint authentication, RFID, and barcode identification were also incorporated to ensure safe and accurate dispensing. Results from these studies demonstrated improved medication adherence, better inventory management, and enhanced patient satisfaction, particularly in rural and emergency healthcare settings. However, the authors also identified challenges including high installation cost, maintenance requirements, dependency, lack of standardized performance evaluation, and limited clinical validation. Overall, these studies indicate that automated medicine dispenser vending machines have strong potential to create a more reliable, efficient, and intelligent healthcare infrastructure, while future research should focus on improving cost-effectiveness, reliability, and system security through the integration of artificial intelligence and cloud computing technologies. Finally, the literature indicates that automated medicine dispenser vending machines significantly reduce the workload of pharmacists, minimize human errors, and ensure continuous availability of medicines. These systems also contribute to improved inventory control and better patient data management. However, challenges remain in terms of cost, maintenance, software security, and compliance with healthcare regulations. Some studies also reported limitations related to mechanical reliability, patient education, and network connectivity, particularly in rural areas. Future research aims to develop cost-effective, scalable, and secure systems that can integrate seamlessly with hospital information systems, electronic prescriptions, and telemedicine platforms. By addressing these challenges, automated medicine dispensers can play a crucial role in building a smarter and more efficient healthcare infrastructure.

III. RESEARCH METHODOLOGY

The block diagram shows that the automated medicine dispensing system involves several stages, starting from prescription generation to medicine delivery. First, the doctor examines the patient and uploads the prescription to a digital platform. The prescription is stored in a database and linked to a unique patient ID.

This ensures that each patient's medication details can be securely accessed when needed. Next, the patient visits the dispensing machine and enters their unique ID through a touchscreen or keypad. The system retrieves the stored prescription from the database and displays the list of prescribed medicines on the screen. The patient can review the medicines and modify the quantity if permitted by the system. After the patient confirms the request, the control unit processes the information and sends commands to the dispensing mechanism. Motors, sensors, and compartments inside the machine work together to locate the required medicines and dispense the correct quantity. Sensors verify the medicine selection and ensure accurate dispensing.

Finally, the medicines are delivered through the output tray to the patient. The system updates the database to record the transaction and maintain inventory levels. This methodology enables a fast, accurate, and automated medicine distribution process with minimal human assistance, making it highly useful in hospitals and healthcare centers that require continuous service.

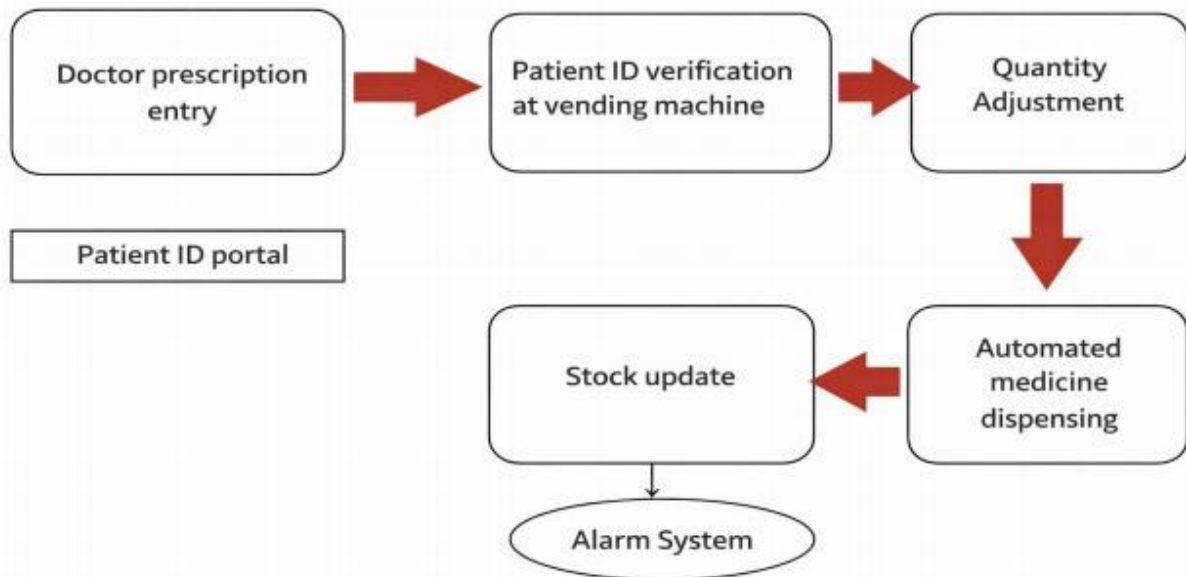

FIG: 1

IV. RESULTS AND DISCUSSION

The proposed automated medicine dispenser vending system was successfully designed and simulated using the Proteus environment with an Arduino Uno (ATmega328P) as the core controller. The simulation results confirm that the system performs all intended operations with satisfactory accuracy and reliability.

Upon user interaction through the keypad interface, the system accurately detects and processes the input commands. The selected medicine is displayed on the 20×4 LCD module, providing clear and real-time feedback to the user. The display messages, such as “Dispensing: Paracetamol,” indicate that the system correctly maps user inputs to predefined medicine options stored in the microcontroller program.

The control logic implemented in the Arduino ensures proper activation of the dispensing mechanism. The relay module, driven through a BC548 transistor, successfully switches the DC motor ON and OFF based on the control signals. The inclusion of a flyback diode (IN4001) effectively protects the circuit from voltage spikes caused by the inductive load, ensuring stable operation.

Additionally, the LED indicators provide visual confirmation of system status. The green LED signifies successful dispensing operations, while the red LED can be configured to indicate errors such as invalid input or system faults. This enhances the overall usability and user experience.

From a performance perspective, the system demonstrates:

- Accurate input recognition from the keypad
- Reliable display output on the LCD
- Stable switching operation of the relay and motor
- Effective integration of hardware and control logic

The results validate that the system is capable of reducing manual intervention in medicine dispensing processes. It offers a low-cost and efficient solution for automating pharmaceutical distribution in environments such as hospitals, clinics, and medical stores.

However, certain limitations were observed in the simulated model. The system currently operates on a predefined set of medicines without dynamic inventory tracking. Furthermore, it lacks advanced features such as secure user

authentication, real-time database integration, and payment gateway support, which are essential for real-world deployment.

Future enhancements can include the integration of IoT-based monitoring systems, automated stock management, and digital payment systems to improve scalability and functionality.

In conclusion, the simulation results demonstrate that the proposed system is technically feasible and provides a strong foundation for developing a fully automated medicine dispensing solution with enhanced features for practical applications.

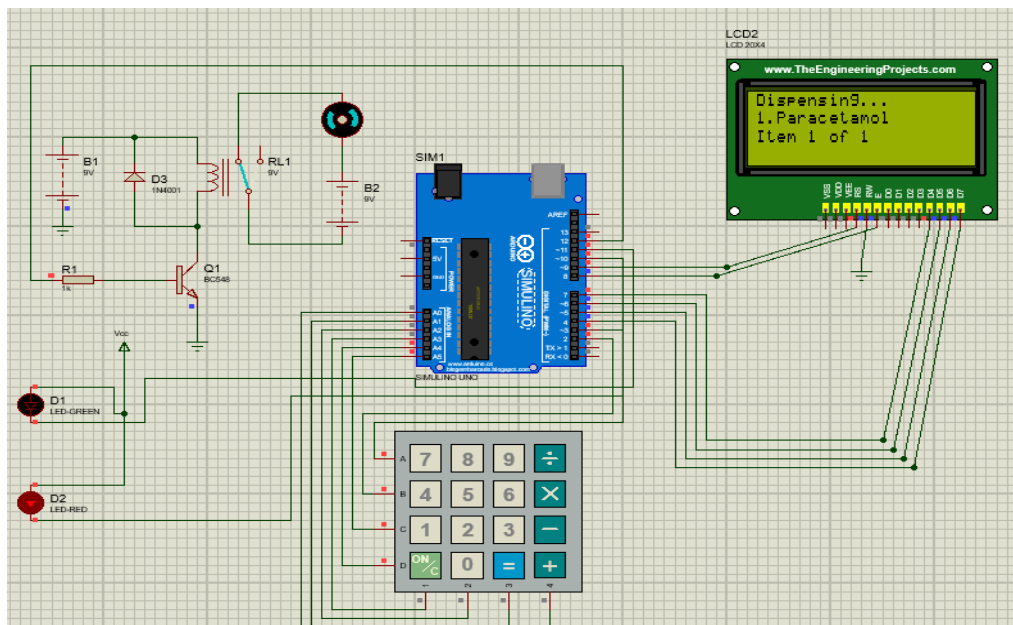

FIG: 2

V. CONCLUSION

The automated medicine dispensing system developed in this project successfully demonstrates the use of embedded technology to improve efficiency and accuracy in healthcare services. The system is capable of verifying user IDs, displaying appropriate instructions, and controlling access to medicines in a secure and reliable manner.

The integration of keypad input, LCD display, and microcontroller processing ensures smooth and userfriendly operation. The results show that the system reduces the need for manual intervention, minimizes human errors, and speeds up the dispensing process. Its simple design, low cost, and ease of implementation make it a practical solution for hospitals, pharmacies, and remote healthcare centers.

In conclusion, the proposed system provides an effective and scalable approach to automated medicine distribution. With further enhancements such as IoT integration, database connectivity, and advanced authentication methods, the system can be expanded into a more intelligent and fully automated healthcare solution.

VI. FUTURE WORK

1. Integration of **IoT technology** for real-time monitoring and remote control
2. Implementation of **biometric authentication** (fingerprint/face recognition) for enhanced security
3. Connection to **cloud-based prescription systems** for direct doctor input
4. Development of a **mobile application** for user interaction and medicine tracking
5. Addition of **digital payment options** (UPI, card, etc.)
6. Use of **advanced sensors and smart motors** for precise dispensing



REFERENCES

1. S. Kumar, R. Gupta, and A. Sharma "IoT- Based Smart Medicine Dispenser System," International Journal of Advanced Research in Electrical, Electronics and Instrumentation Engineering, vol. 8, no. 4, pp. 1120-1126, 2024
2. A. Patel and R. Singh, "Design and Development of an Automated Medicine Vending Machine Using Microcontroller," Journal of Biomedical Systems and Technologies, vol. 12, no. 2, pp. 45-52, 2023
3. D. Sharma, M. Verma, and K. Nair, "Smart Health Monitoring and Medicine Dispensing System," IEEE Conference on Healthcare Innovation and Automation, pp. 89-93, 2022.
4. P. Jadhav, S. Pawar, and A. Bhosale, "Automatic Pill Dispenser Using Arduino," International Journal of Engineering Research & Technology (IJERT), vol. 9, no. 5, pp. 250-254, 2023
5. M. R. Raj, "Development of a Smart Medicine Dispenser for Elderly Patients," International Journal of Smart Device and System Design, vol. 5, no. 3, pp. 101-107, 2024
6. K. Thomas and L. Devi, "Design of an IoT- Based Automatic Medicine Dispenser," International Research Journal of Engineering and Technology (IRJET), vol. 11, no. 2, pp. 330-334, 2024.
7. R. Mehta and T. Sinha, "Automation in Healthcare: Intelligent Drug Dispensing Systems," IEEE Transactions on Biomedical Engineering, vol. 71, no. 7, pp. 1205-1213, 2023
8. N. Bhatia, "Embedded System Approach for Automated Medicine Distribution," International Conference on Intelligent Healthcare Systems, pp. 56-60, 2023
9. C.Nagarajan and M.Madheswaran - 'Stability Analysis of Series Parallel Resonant Converter with Fuzzy Logic Controller Using State Space Techniques'- Taylor & Francis, Electric Power Components and Systems, Vol.39 (8), pp.780-793, May 2011. DOI: 10.1080/15325008.2010.541746
10. C.Nagarajan and M.Madheswaran - 'Experimental verification and stability state space analysis of CLL-T Series Parallel Resonant Converter' - Journal of Electrical Engineering, Vol.63 (6), pp.365-372, Dec.2012. DOI: 10.2478/v10187-012-0054-2
11. C.Nagarajan and M.Madheswaran - 'Performance Analysis of LCL-T Resonant Converter with Fuzzy/PID Using State Space Analysis'- Springer, Electrical Engineering, Vol.93 (3), pp.167-178, September 2011. DOI 10.1007/s00202-011-0203-9
12. S.Tamilselvi, R.Prakash, C.Nagarajan, "Solar System Integrated Smart Grid Utilizing Hybrid Coot-Genetic Algorithm Optimized ANN Controller" Iranian Journal Of Science And Technology-Transactions Of Electrical Engineering, DOI10.1007/s40998-025-00917-z,2025
13. S.Tamilselvi, R.Prakash, C.Nagarajan, "Adaptive sliding mode control of multilevel grid-connected inverters using reinforcement learning for enhanced LVRT performance" Electric Power Systems Research 253 (2026) 112428, doi.org/10.1016/j.epsr.2025.112428
14. S.Thirunavukkarasu, C. Nagarajan, 2024, "Performance Investigation on OCF and SCF study in BLDC machine using FTANN Controller," Journal of Electrical Engineering And Technology, Volume 20, pages 2675-2688, (2025), doi.org/10.1007/s42835-024-02126-w
15. C. Nagarajan, M.Madheswaran and D.Ramasubramanian- 'Development of DSP based Robust Control Method for General Resonant Converter Topologies using Transfer Function Model'- Acta Electrotechnica et Informatica Journal , Vol.13 (2), pp.18-31, April-June.2013, DOI: 10.2478/aeeci-2013-0025.
16. C.Nagarajan and M.Madheswaran - 'DSP Based Fuzzy Controller for Series Parallel Resonant converter'- Springer, Frontiers of Electrical and Electronic Engineering, Vol. 7(4), pp. 438-446, Dec.12. DOI 10.1007/s11460-012-0212-0.
17. C.Nagarajan and M.Madheswaran - 'Experimental Study and steady state stability analysis of CLL-T Series Parallel Resonant Converter with Fuzzy controller using State Space Analysis'- Iranian Journal of Electrical & Electronic Engineering, Vol.8 (3), pp.259-267, September 2012.
18. C.Nagarajan and M.Madheswaran, "Analysis and Simulation of LCL Series Resonant Full Bridge Converter Using PWM Technique with Load Independent Operation" has been presented in ICTES'08, a IEEE / IET International Conference organized by M.G.R.University, Chennai. Vol.no.1, pp.190-195, Dec.2007
19. Suganthi Mullainathan, Ramesh Natarajan, "An SPSS and CNN modelling based quality assessment using ceramic materials and membrane filtration techniques", Revista Materia (Rio J.) Vol. 30, 2025, DOI: <https://doi.org/10.1590/1517-7076-RMAT-2024-0721>
20. M Suganthi, N Ramesh, "Treatment of water using natural zeolite as membrane filter", Journal of Environmental Protection and Ecology, Volume 23, Issue 2, pp: 520-530,2022
21. S. Priya, V. Kumar, and P. Das, "Design of Smart Medicine Box Using IoT," International Journal of Emerging Trends in Engineering Research, vol. 10, no. 8, pp. 453-459, 2022.
22. R. Ali and H. Noor, "Automation of Drug Dispensing Systems in Smart Hospitals," Journal of Medical Automation and Robotics, vol. 6, no. 1, pp. 25-31, 2024



23. Mathew, A., & Alex, H. (2023). From Code to Cure: The Role of AI in Accelerating Drug Discovery. *Advances and Challenges in Science and Technology* Vol. 2, 94-102.
24. Vimal, V. R., John Justin Thangaraj, S., Narayanan, L. K., Alagu Thangam, S., Loganayagi, S., & Balakrishnan, S. (2025, April). Enhanced Phishing Detection and Classification Using an Ensemble Machine Learning Approach for URL Analysis. In *International Conference on Information and Communication Technology for Intelligent Systems* (pp. 229-239). Springer Nature Singapore.
25. Mathew, A. (2021). Obfuscation Techniques for Magecart Detection and Prevention. *International Journal of Computer Science and Mobile Computing*, 10(2), 39-44.