



# Multicarrier CDMA with OFDM for Data-Centric Applications and Performance Analysis

Dr.N.Sureshkumar<sup>1</sup>, B.Gokila<sup>2</sup>, S.Durgadevi<sup>3</sup>, G.Swathi<sup>4</sup>

Muthayammal Engineering College, Rasipuram, Tamil Nadu, India<sup>1</sup>

Department of Electronics and Communication Engineering, Muthayammal College of Engineering, Rasipuram, Tamil Nadu, India<sup>2-4</sup>

**ABSTRACT:** In 4G wireless communication systems, Multi-Carrier Code Division Multiple Access (MC-CDMA) is one suitable choice to achieve high data rate. MC-CDMA is the combination of CDMA and OFDM schemes, resulting in to getting the advantage of both the schemes. In this paper the performance analysis of MC-CDMA for different spreading codes, modulation techniques and receiver diversities are carried out. Hence achieving increased BER performance and thereby increasing the total capacity by mitigating the effect of Multipath Interference (MI) and Multiple Access Interferences (MAI) using MC-CDMA.

**KEYWORDS:** MC-CDMA,NGN,QPSK,AWGN,CP,MAI,MI, OFDM,FFT,IFFT,MRC,BER

## I. INTRODUCTION

Over the decade the focus of wireless communication has shifted from voice to multimedia and data. It became a challenging task to accommodate more users in a limited spectrum. In its evolution from analog first generation technology (1G) to digital second generation technology (2G), General Packet radio Service (GPRS) and Enhanced Data for GSM Evolution (EDGE), enhanced the data capability of GSM platform. The technology counterpart CDMA evolved from IS-95A to IS-95B and CDMA-2000. The introduction of WCDMA technology is termed as third generation technique (3G) which ensures 2Mbps throughput for user as per IMT-2000 standard [7]. Wider bandwidth is required to support a higher data rate in a single carrier transmission. To overcome the frequency selectivity of the wideband channel experienced by single-carrier transmission, multiple carriers can be used for high rate data transmission. Since the subcarriers are maintaining orthogonality among themselves the Inter-carrier Interference (ICI) can be suppressed leading to distortion less transmission. Orthogonal Frequency Division Multiplexing (OFDM) [13] is a multi-carrier transmission technique. It is a low-complexity technique to efficiently modulate multiple sub-carriers by using digital signal processing.

To achieve high data rate Multi-carrier code division multiple access (MC-CDMA) is one suitable choice for NGN CDMA based wireless communication system. MC-CDMA is a combination of CDMA and OFDM schemes and is one of the promising 4G technique. The principle of OFDM-CDMA is to map the chips of a spread data symbol in frequency direction over several in the parallel sub-channels. OFDM-CDMA inherits merits of OFDM and DS-SS-CDMA [1], which has a fine performance. Capacity planning is one of the major issue in designing of wireless communication system. The main objective of this paper is to increase the BER performance and thereby increasing the total capacity by mitigating the effect of Multipath Interference (MI) and Multiple Access Interferences (MAI) using MC-CDMA. Here the Performance Analysis of the OFDM-CDMA for different spreading code length and for different active users are carried out. The digital modulation considered as (QPSK) in conjunction with Spread Spectrum. The spreading modulation used is the orthogonal Gold codes. The channel model used is Average White Gaussian noise (AWGN). Diversity technique used in the receiver is MRC (Maximal Ratio Combining) which will reduce MI. Eb/No Vs BER plot for 64 point IFFT/FFT based OFDM is also plotted for different noise models like AWGN, Rayleigh fading etc. For an effective interference system performance improvement of OFDM is done by introducing the concept of Cyclic prefixing (CP), which will reduce MAI.

## III. SPREADING CODES

The MC-CDMA orthogonal spreading codes are one of the major elements within the whole CDMA system. The CDMA orthogonal spreading codes are combined with the data stream to be transmitted in such a way that the bandwidth required is increased and the benefits of the spread spectrum system can be gained. Figure 1. shows the

concept of CDMA, is based around the fact that a data sequence is multiplied by a spreading code or sequence which increases the bandwidth of the signal. Then within the receiver the same spreading code or sequence is used to extract the required data. Only when the required code is used, does the required data appear from the signal. The process of extracting the data is called correlation. When a code exactly the same as that used in the transmitter is used, then it is said to have a correlation of one and data is extracted. When a spreading code [10] that does not correlate is used, then the data will not be extracted and a different set of data will appear. This means that it is necessary for the same spreading code to be used within the transmitter and receiver for the data to be extracted.

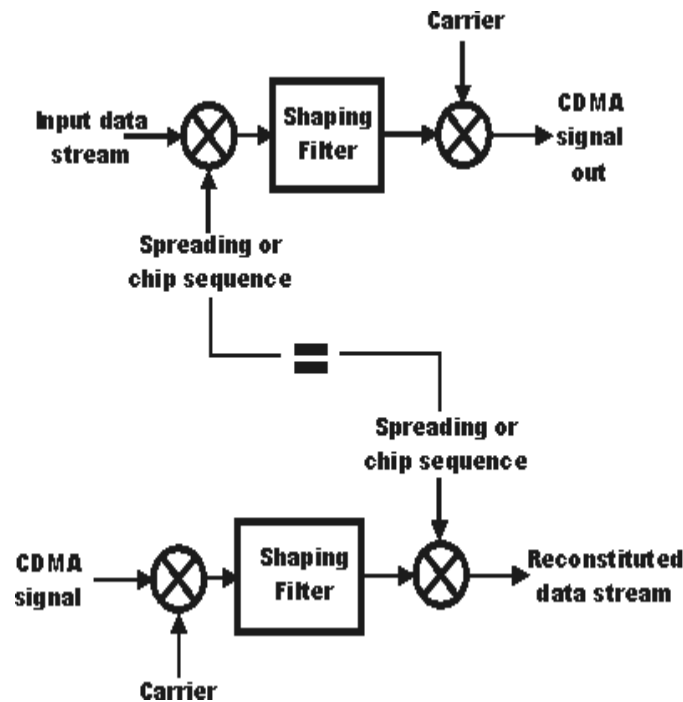

Figure 1. CDMA system showing use of spreading codes

A. Using Walshcode

The Walsh–Hadamard code is used to define individual communication channels. It is usual in the CDMA literature to refer to codewords as “codes”. Each user will use a different codeword, or “code”, to modulate their signal. Because Walsh–Hadamard codewords are mathematically orthogonal, a Walsh-encoded signal appears as random noise to a CDMA capable mobile terminal, unless that terminal uses the same codeword as the one used to encode the incoming signal. Orthogonal codes are easily generated by starting with a seed of 0, repeating the 0 horizontally and vertically, and then complementing the 1 diagonally [4]. This process is to be continued with the newly generated block until the desired codes with the proper length are generated. Sequences created in this way are referred to as “Walsh” code. The Walsh code is used to separate the user in the forward CDMA link. In any given sector, each forward code channel is assigned a distinct Walsh code.

B. Gold Codes

Orthogonal codes must have good correlation properties to mitigate MAI. W-H code has poor correlation properties and it behaves diversely resulting in a large number of BER levels thereby putting some users at disadvantage. When mobile-to-base links cannot be precisely coordinated, particularly due to the mobility of the handsets, a different approach is required. Since it is not mathematically possible to create signature sequences that are both orthogonal for arbitrarily random starting points and which make full use of the code space, unique "pseudo-random" or "pseudo-noise" (PN) sequences are used in asynchronous CDMA systems. A PN code is a binary sequence that appears random but can be reproduced in a deterministic manner by intended receivers. These PN codes are used to encode and decode a user's signal in Asynchronous CDMA in the same manner as the orthogonal codes in synchronous CDMA (shown in the example above). These PN sequences are statistically uncorrelated, and the sum of a large number of PN sequences results in multiple access interference (MAI) that is approximated by a Gaussian noise process (following the central limit theorem in statistics). Gold codes are an example of a PN suitable for this purpose, as there is low correlation between the codes. If all of the users are received with the same power level, then the variance (e.g., the noise power)



of the MAI increases in direct proportion to the number of users. In other words, unlike synchronous CDMA, the signals of other users will appear as noise to the signal of interest and interfere slightly with the desired signal in proportion to number of users. Signals become more sensitive to non linearities of transmitter for high peak average to power ratio. In uplink PAPR can be reduced by Golay code[12].

IV. MULTICARRIER CDMA

The most important objectives in the 4th generation wireless mobile communication systems are to enable the integration of existing technologies in a unified platform, to take care of the severe Inter-Symbol Interference (ISI), to provide high speed data transmission rate in a spectrally efficient manner with utilizing the available limited bandwidth and to achieve low cost and reduced complexity receivers and their signal processing solutions for high quality communication. Multicarrier techniques on multi-path fading environment can be one of the best solutions to achieve the above performance. Due to the limitations of Orthogonal Frequency Division Multiplexing (OFDM) and Code Division Multiple Access (CDMA), Multi-Carrier Code Division Multiple Access (MC-CDMA)[9] which is a multiple access scheme generated by the combination of OFDM and CDMA has received much attention . Each user symbol in the frequency domain is spreaded by the MC-CDMA. In other word, each user symbol is phase shifted according to a code value and carried over multiple parallel sub-carriers. However, the code values differ per sub-carrier and per user. All sub-carrier signals are merged at the receiver and undo the code shift. Then the receiver separates signals of different users. So, the network can accommodate many users within a given frequency band . It has many other advantages like robustness to channel dispersion, high frequency spectrum efficiency and high data transmissions.

A. OFDM Based Multicarrier Transmission

In the last years wireless communications have experienced a fast growth due to the high mobility that they allow. However, wireless channels have some disadvantages, like multi-path fading, that make them difficult to deal with. A modulation that efficiently deals with selective fading channels is orthogonal frequency division multiplexing (OFDM)[9], which consists on N orthogonal subcarriers generated and modulated in frequency domain. Figure 2 shows the OFDM model. Multicarrier transmission splits the high-rate data stream into N substreams of lower data rate. Classical parallel-data systems divide the available bandwidth into N non overlapping subchannels. Each subchannel is modulated with a separate symbol and then the N subchannels are frequency multiplexed. This way interchannel interference is eliminated but it leads to poor spectral efficiency. In order to use the spectrum more efficiently it was proposed to use overlapping subchannels, but in overlapping subchannels it is necessary to eliminate crosstalk between subcarriers, which means that the different modulated subcarriers have to be orthogonal to each other. Orthogonal means that there is a precise mathematical relationship between the frequencies of the carriers of the system. The fact that the subcarriers are orthogonal allows the usage of the Fourier transform without introducing inter-carrier interference (ICI). The advancements in digital signal processing and very large scale integrated circuits allow efficient and cost-effective implementation of the fast Fourier transform (FFT) operations making OFDM an attractive solution for wireless channels.

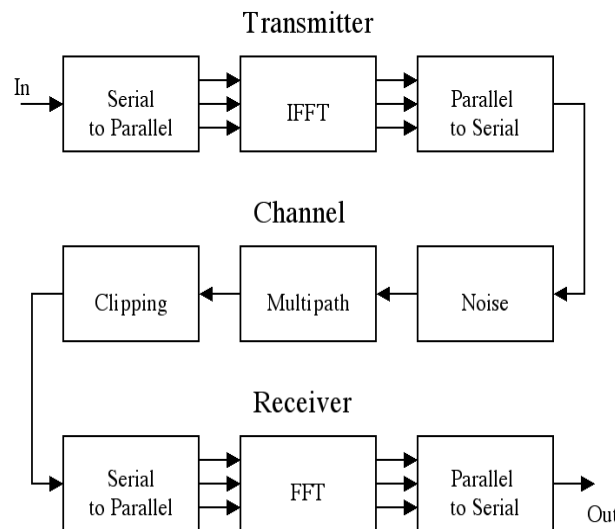

Figure 2 . OFDM model



V. SYSTEM MODEL

A. Transmitter Model

Figure 3 shows the simulation model of MC-CDMA transmitter. Randomly generated user data are randomized and output of randomizer is fed to forward error correction (FEC) block where randomized data are coded by Reed Solomon and convolutional encoder. FEC code has high gain and adopted in WCDMA and WiMAX standards. Viterbi algorithm is used for decoding the convolutional coding. Output of FEC code is interleaved and modulated. For modulation QPSK used. Modulated output is spreaded by Gold spreading code in frequency domain then transmitted simultaneously on Nc parallel subcarriers.

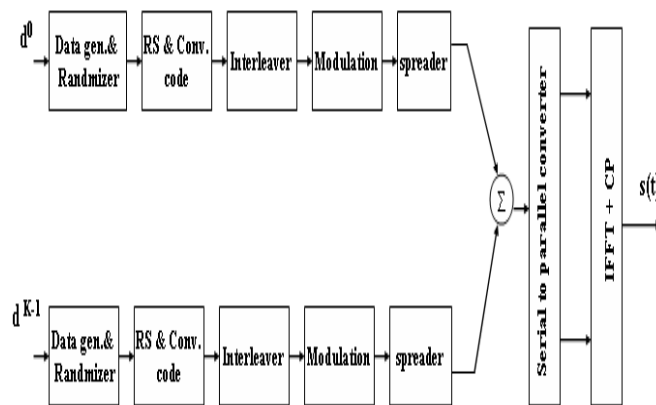

Figure 3. MC-CDMA transmitter model

These parallel subcarriers are orthogonal to each other and can be generated by using Inverse Fast Fourier transform (IFFT). After this cyclic prefix is used as a guard interval to minimize the effect of inter carrier interference (ICI). Now parallel to serial converter (P/S) converts parallel data into serial data stream and transmit over channel. The transmitted baseband signal for the kth user is given by

$$s_k(t) = \sum_{i=1}^{\infty} \sum_{n=1}^{N_c} d_k(i) p_{T_b}(\sqrt{t - iT_b}) a_{k,n}(n) \cos(\omega_n t + \theta_{k,n}) \quad i = -\infty \quad n$$

(1)

Where K is the number of the active user, i is the number of the information symbol Nc is the total number of subcarrier, Pk is the transmitted power of kth user, dk(i) is the ith binary data sequence of kth user, ak(n) is the spreading sequence on nth subcarrier of kth user, wn is the carrier frequency and α k,n is the phase of the nth subcarrier for kth user which is independent and identically distributed over [0, 2π] interval .

p Tb is the rectangular symbol pulse waveform defined as

$$p_{T_b} = 1 \quad \text{For } 0 \leq t \leq T_b$$

$$= 0 \quad \text{Otherwise} \quad (2)$$

B. Channel Model

The channel is assumed additive white Gaussian(AWGN) on each subcarrier. Complex equivalent of this channel is described as,

$$Y(n) = V(\theta)s(n) + G(n) \quad (3)$$

Where, V (θ) is the array manifold vector and G (n) is AWGN with zero mean and two-sided power spectral density given by No/2.

C. Receiver Model

Receiver model of MC-CDMA is shown in Figure 4.

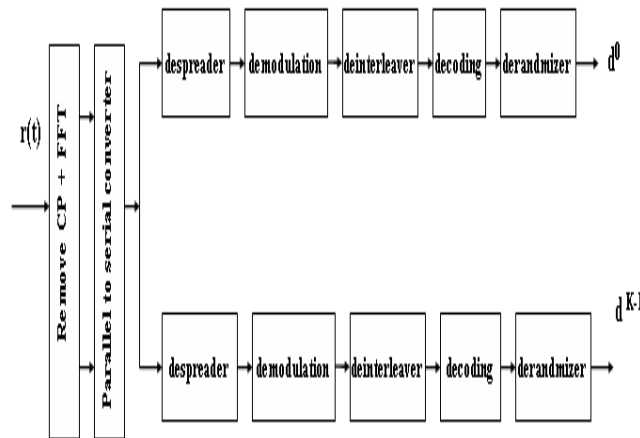

Figure 4. MC-CDMA receiver model

At receiver first convert serial data into parallel by serial to parallel converter (S/P) then remove the cyclic prefix and take the Fast Fourier Transform (FFT) of received signal. After that despread and demodulate the users signal. The output of demodulator passes through the channel decoder. The decoded output is derandomized and obtained the users data.

#### D. Receiver Diversity

Antenna diversity, also known as space diversity, is any one of several wireless diversity schemes that uses two or more antennas to improve the quality and reliability of a wireless link. Often, especially in urban and indoor environments, there is no clear line-of-sight(LOS) between transmitter and receiver. Instead the signal is reflected along multiple paths before finally being received. Each of these bounces can introduce phase shifts, time delays, attenuations, and distortions that can destructively interfere with one another at the aperture of the receiving antenna.

Antenna diversity is especially effective at mitigating these multipath situations. This is because multiple antennas offer a receiver several observations of the same signal. Each antenna will experience a different interference environment. Thus, if one antenna is experiencing a deep fade, it is likely that another has a sufficient signal. Collectively such a system can provide a robust link

In this paper we introducing Maximal-Ratio combining as a receiver diversity technique for mitigating the effect of MPI. The properties of maximal-ratio combining are,

- All paths cophased and summed with optimal weighting to maximize combiner output SNR
- Optimal technique to maximize output SNR
- A means of combining the signals from all receiver branches, so that signals with a higher received power have a larger influence on the final output.

### VI. PERFORMANCE ANALYSIS

BER Vs Eb/No Performance Analysis was done for the transceiver .Bit Error rate is averaged for finite number of iteration and mean value is taken. The performance of Receiver diversity block is tested with and without diversity component. The performance of the Maximal Ratio combiner is being tested. Similarly unitary codes are defined as orthogonal codes which are allocated on a unitary basis. ie, One code is allocated per user at a time. The orthogonal unitary codes are being analysed for their BER performance.

### VII. SIMULATION RESULTS

Proposed implementation of MC-CDMA transceiver as described in section IV was simulated using MATLAB Version 7.10 R2010a.

Each block of MC-CDMA transmitter and receiver is individually coded. Reed Solomen and convolution code is used as a channel coding. Figure 5& 6 shows the results for MC-CDMA with OFDM along with receiver diversity, different types of receiver diversity are tried in the system. Results shows that MC-CDMA with maximal ratio combining will



provide better results than Equal gain combining. MC-CDMA with spreading code as both W-H codes and Gold codes are tried. The performance analysis of Walsh Hadamard and Gold codes are analysed and plotted.

Figure 7 shows comparison of orthogonal unitary codes, walsh codes and gold codes. From here we can analyze gold codes has the better BER performance. Complementary Keying codes are of superior performance

In Figure 8 a comparison of BER performance is made among the different modulation techniques. Spreading code length is 16, active users are taken as 10. Coding rates for QPSK are taken as  $\frac{1}{2}$  and  $\frac{3}{4}$  and for 16-QAM taken as  $\frac{1}{2}$  and  $\frac{3}{4}$ . For BPSK and QPSK BER is decreasing with channel SNR but for QAM BER is nearly constant for any value of SNR. Performance of QPSK with  $\frac{1}{2}$  coding rate is better than the  $\frac{3}{4}$  coding rate.

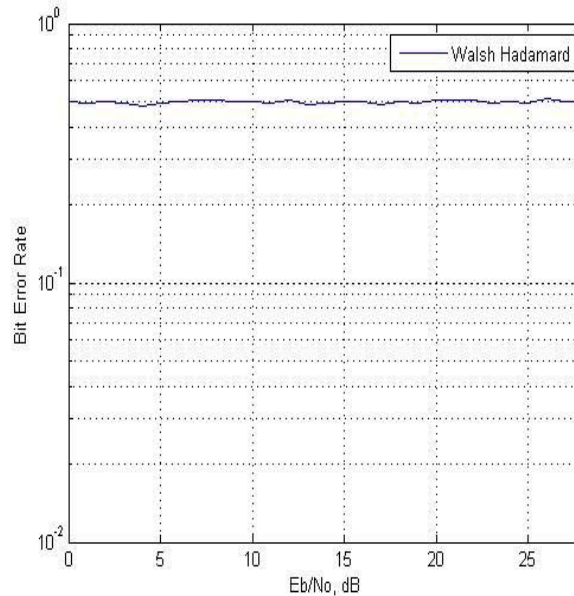

Figure 5. MC-CDMA with OFDM without receiver diversity

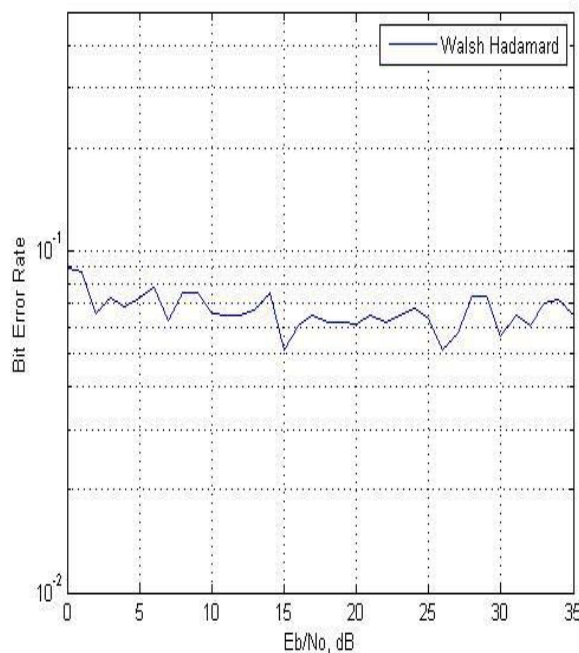

Figure 6. MC-CDMA with OFDM and receiver diversity as maximal ratio combining.

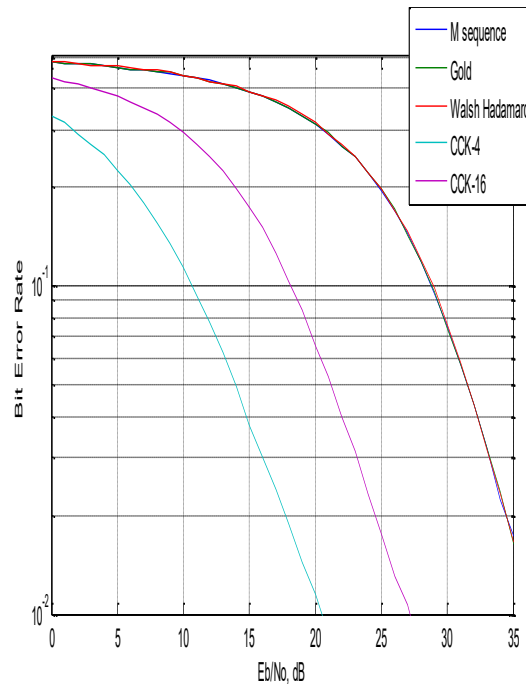

Figure 7. Orthogonal Unitary Codes Walsh Hadamard and Gold are compared .

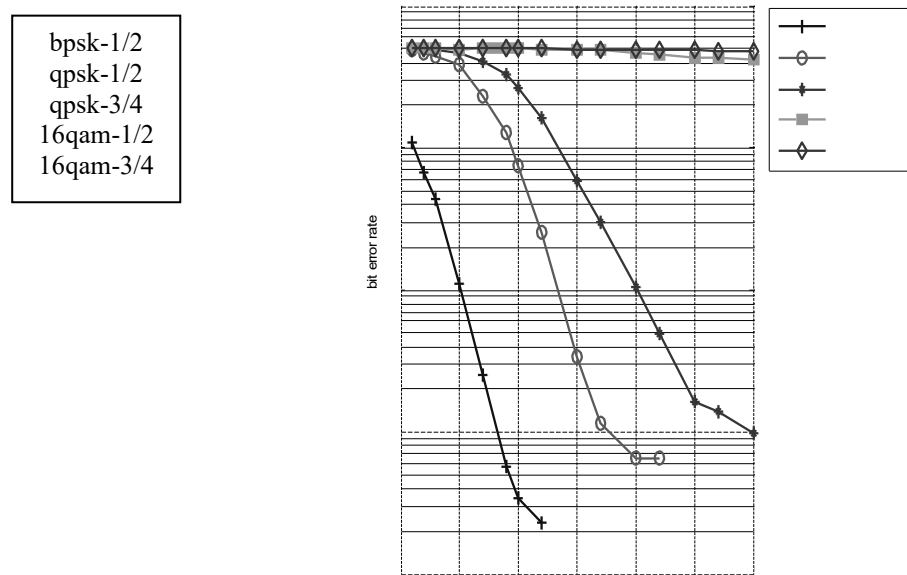

Figure 8. BER versus SNR at different modulation techniques of coded MC- CDMA system.

### VIII. CONCLUSIONS

In this paper we analysed the MC-CDMA system over additive white gaussian channel. Improved BER performance will increase the capacity of the system. MAI and MI may reduce the performance of the system. So ,orthogonal gold codes are introduced for mitigating MAI and maximal-ratio combining diversity technique are used to mitigate the effect of MI. Cyclic prefixing is also introduced. From simulation results it is observed that BER performance is significantly improved with an increasing length of spreading code and BER performance degrades with an increasing



the number of active users. Comparing the performance among the BPSK, QPSK modulation techniques, it is shown that QPSK can provide substantial performance improvement over BPSK.

## IX. ACKNOWLEDGMENT

The authors would like to thank all the staffs of Department of Electronics and communication at Ranipettai Engineering College, Vellore, for their valuable suggestions.

## REFERENCES

1. S. Hara and R. Prasad., "Overview of Multicarrier CDMA," IEEE Communications Magazine, vol. 35, pp. 126–133, Dec. 1997.
2. A.A. Patel, A.D. Patel, "Matlab Implementation of Multiuser Code division Multiple Access, Journal of Telecommunications, vol. 7, issue 2, pp. 40-45, March 2011.
3. P. Kumar, M. Ramesh, S. Chakrabarti, "Performance Evaluation of Orthogonal/Scrambled-Orthogonal Overloaded DS-CDMA System", Wireless and Optical Communications Networks, pp. 1-5, July 2007.
4. Hanna Bogucka, "Effectiveness and performance analysis of various spreading codes applied in multicarrier CDMA wireless systems" IEEE Wireless Communications and Networking Conference, vol.2, pp. 681 – 685, 2000.
5. Fei Qin, Mitchell, J.E., "Performance estimation of adaptive spreading code length for energy efficient WSN", Wireless Advanced (WiAd), pp.81-84, June 2011.
6. Sadek Ali, Md. Shariful Islam, Md. Alamgir Hossain, Md. Khalid Hossain Jewel, "BER Analysis of Multi-Code Multi-Carrier CDMA Systems in Multipath Fading Channel", International Journal of Computer Networks & Communications (IJCNC) vol.3, No.3, pp. 178-191, May 2011.
7. Makoto Miyake, "A Survey on Progress and Standardization Trends in Wireless Communications", Journal of communications, vol. 4, No. 7, pp. 509-520. August 2009.
8. K.R. Shankar kumar and A. Choklingum, "Parallel Interference Cancellation for Multicarrier DS CDMA Systems," IEEE Communications Society, pp.2874-2877, 2004.
9. C.Nagarajan and M.Madheswaran - 'Stability Analysis of Series Parallel Resonant Converter with Fuzzy Logic Controller Using State Space Techniques'- Taylor & Francis, Electric Power Components and Systems, Vol.39 (8), pp.780-793, May 2011. DOI: 10.1080/15325008.2010.541746
10. C.Nagarajan and M.Madheswaran - 'Experimental verification and stability state space analysis of CLL-T Series Parallel Resonant Converter' - Journal of Electrical Engineering, Vol.63 (6), pp.365-372, Dec.2012. DOI: 10.2478/v10187-012-0054-2
11. C.Nagarajan and M.Madheswaran - 'Performance Analysis of LCL-T Resonant Converter with Fuzzy/PID Using State Space Analysis'- Springer, Electrical Engineering, Vol.93 (3), pp.167-178, September 2011. DOI 10.1007/s00202-011-0203-9
12. S.Tamilselvi, R.Prakash, C.Nagarajan, "Solar System Integrated Smart Grid Utilizing Hybrid Coot-Genetic Algorithm Optimized ANN Controller" Iranian Journal Of Science And Technology-Transactions Of Electrical Engineering, DOI10.1007/s40998-025-00917-z,2025
13. S.Tamilselvi, R.Prakash, C.Nagarajan, "Adaptive sliding mode control of multilevel grid-connected inverters using reinforcement learning for enhanced LVRT performance" Electric Power Systems Research 253 (2026) 112428, doi.org/10.1016/j.epr.2025.112428
14. S.Thirunavukkarasu, C. Nagarajan, 2024, "Performance Investigation on OCF and SCF study in BLDC machine using FTANN Controller," Journal of Electrical Engineering And Technology, Volume 20, pages 2675–2688, (2025), doi.org/10.1007/s42835-024-02126-w
15. Nagarajan, M.Madheswaran and D.Ramasubramanian- 'Development of DSP based Robust Control Method for General Resonant Converter Topologies using Transfer Function Model'- Acta Electrotechnica et Informatica Journal , Vol.13 (2), pp.18-31, April-June.2013, DOI: 10.2478/aei-2013-0025.
16. C.Nagarajan and M.Madheswaran - 'DSP Based Fuzzy Controller for Series Parallel Resonant converter'- Springer, Frontiers of Electrical and Electronic Engineering, Vol. 7(4), pp. 438-446, Dec.12. DOI 10.1007/s11460-012-0212-0.
17. C.Nagarajan and M.Madheswaran - 'Experimental Study and steady state stability analysis of CLL-T Series Parallel Resonant Converter with Fuzzy controller using State Space Analysis'- Iranian Journal of Electrical & Electronic Engineering, Vol.8 (3), pp.259-267, September 2012.
18. C.Nagarajan and M.Madheswaran, "Analysis and Simulation of LCL Series Resonant Full Bridge Converter Using PWM Technique with Load Independent Operation" has been presented in ICTES'08, a IEEE / IET International Conference organized by M.G.R.University, Chennai.Vol.no.1, pp.190-195, Dec.2007



19. Suganthi Mullainathan, Ramesh Natarajan, “An SPSS and CNN modelling based quality assessment using ceramic materials and membrane filtration techniques”, *Revista Materia (Rio J.)* Vol. 30, 2025, DOI: <https://doi.org/10.1590/1517-7076-RMAT-2024-0721>
20. M Suganthi, N Ramesh, “Treatment of water using natural zeolite as membrane filter”, *Journal of Environmental Protection and Ecology*, Volume 23, Issue 2, pp: 520-530,2022
21. V. Jagan naveen, K.Muralikrishna, K.Rajarajeshwari , “Performance Analysis of MC-CDMA and OFDM in Wireless Rayleigh Channel” *journal of advanced science and tech.*,vol.25 pp.17-30,dec-2010.
22. Branislav M. Popović, “Spreading Sequences for Multicarrier CDMA systems”, *IEEE Transactions On Communications*, vol. 47,No.6, pp. 918-926, June 1999.
23. Antonia M. Tulino, Member, IEEE, Linbo Li, and Sergio Verdú, Fellow, IEEE , “Spectral Efficiency of Multicarrier CDMA” *IEEE Transactions On Information Theory*, Vol. 51,No.2, pp.479-503, February 2005.
24. Sanjay Singh, M Sathish Kumar, and H. S Mruthyunjaya , “A Performance Comparison of Golay and Reed-Muller Coded OFDM Signal for Peak-to-Average Power Ratio Reduction” , *International Journal of Electrical and Computer Engineering* 4:14 2009, pp.892-897.
25. A.C.McCormick and E.A.Al-Susa, “Multicarrier CDMA for Future Generation Mobile Communication”, *Journal of Electronics and Communication Engineering*,pp.52-60,April 2002.
26. Vasu Chakravarthy, Abel S. Nunez, And James P. Stephens, Air Force Research Laboratory , Arnab K. Shaw, Wright State University, Michael A. Temple, Air Force Institute Of Technology, “TDCS, OFDM, and MC-CDMA: A Brief Tutorial” , *IEEE Radio Communications* ,pp.s11-s15,September 2005.
27. Zhongqiang Luo, Xingzhong Xiong , “Performance Comparison of SC -FDMA-CDMA and OFDM-CDMA Systems for Uplink” , *IEEE Transactions on Communications* ,pp. 1475-1479, 2011.
28. **Kiran, A., Rubini, P., & Kumar, S. S. (2025).** Comprehensive review of privacy, utility and fairness offered by synthetic data. *IEEE Access*.
29. **Gopinathan, V. R. (2024).** Real-Time Financial Risk Intelligence Using Secure-by-Design AI in SAP-Enabled Cloud Digital Banking. *International Journal of Computer Technology and Electronics Communication*, 7(6), 9837-9845.
30. **Udayakumar, R., Elankavi, R., Vimal, R., & Sugumar, R. (2023).** Improved Particle Swarm Optimization with Deep Learning-Based Municipal Solid Waste Management in Smart Cities. *Environmental & Social Management Journal*, 17(4).
31. **Anand, L. (2023).** An Intelligent AI and ML-Driven Cloud Security Framework for Financial Workflows and Wastewater Analytics. *International Journal of Humanities and Information Technology*, 5(02), 87-94.
32. **Soundappan, S. J. (2020).** Big Data Analytics in Healthcare: Applications for Pandemic Forecasting. *International Journal of Advanced Research in Computer Science & Technology*, 3(1), 2248-2253.
33. **Rajasekar, M. (2024).** Real-Time Predictive DevOps Intelligence for Risk-Aware Digital Business Processes in Cloud and SAP Ecosystems. *International Journal of Advanced Research in Computer Science & Technology*, 7(4), 10713-10718.
34. **Poornima, G., & Anand, L. (2024, May).** **Novel AI Multimodal Approach for Combating Against Pulmonary Carcinoma. In 2024 5th International Conference for Emerging Technology (INCET) (pp. 1-6).** IEEE.
35. **Prabha, P. S., & Rengarajan, A. (2025).** Adaptive Cloud Resource Allocation Using Attention-Driven Deep Reinforcement Learning. *Engineering, Technology & Applied Science Research*, 15(6), 29334-29340.
36. **Jagadeesh, S., & Sugumar, R. (2017).** A Comparative study on Artificial Bee Colony with modified ABC algorithm. *European Journal of Applied Sciences*, 9(5), 243-248.
37. **Varma, K. K., & Anand, L. (2025, March).** **Deep Learning Driven Proactive Auto Scaler for High-Quality Cloud Services. In International Conference on Computing and Communication Systems for Industrial Applications (pp. 329-338).** Singapore: Springer Nature Singapore.
38. **Kumar, S. A., & Anand, L. (2025).** A Novel EEG-Based Deep Learning Framework for Enhancing Communication in Locked-In Syndrome Using P300 Speller and Attention Mechanisms. *KSII TRANSACTIONS ON INTERNET AND INFORMATION SYSTEMS*, 19(11), 3841-3855.
39. **Poornima, G., & Anand, L. (2025).** Medical image fusion model using CT and MRI images based on dual scale weighted fusion based residual attention network with encoder-decoder architecture. *Biomedical Signal Processing and Control*, 108, 107932.
40. **Archana, R., & Anand, L. (2025).** Residual u-net with Self-Attention based deep convolutional adaptive capsule network for liver cancer segmentation and classification. *Biomedical Signal Processing and Control*, 105, 107665. **Kumar, S. A., & Anand, L. (2025).** A Novel EEG-Based Deep Learning Framework for Enhancing Communication in Locked-In Syndrome Using P300 Speller and Attention Mechanisms. *KSII Transactions on Internet and Information Systems*, 19(11), 3841-3855.



41. **Rengarajan, A. (2025).** Cloud-Based AI-Driven Threat Detection Framework for Smart Grid Cybersecurity. *International Journal of Future Innovative Science and Technology*, 8(6), 16065.
42. **Murugeswari, B., Sudharson, K., Panimalar, S. P., Shanmugapriya, M., & Abinaya, M. (2020).** SAFE-Secure Authentication in Federated Environment using CEG Key code.
43. **Raj A. A., & Sugumar, R. (2023).** Early Detection of COVID-19 with Impact on Cardiovascular Complications using CNN Utilising Pre-Processed Chest X-Ray Images. *2023 International Conference on Applied Intelligence and Sustainable Computing (ICAISC)*, IEEE.
44. **Jagadeesh, S., & Sugumar, R. (2017).** A Comparative study on Artificial Bee Colony with modified ABC algorithm. *European Journal of Applied Sciences*, 9(5), 243-248.
45. **Selvi, G. V., Anbarasan, A. B., Murthy, B. A., & Prabavathy, S. (2023).** An Application Oriented Integrated Unequal Clustering Algorithm for Wireless Sensor Network. In *Underwater Vehicle Control and Communication Systems Based on Machine Learning Techniques* (pp. 140-154). CRC Press.
46. **Sruthi, R. S., Ananya, S., & Murugeswari, B. (2010).** Web Based Virtual Control System Laboratory and On-Line Temperature Control of Electrophoresis Equipment using LabVIEW. *International Journal of Computer Applications*, 975, 8887.
47. **Vimal Raja, G. (2021).** Mining Customer Sentiments from Financial Feedback and Reviews using Data Mining Algorithms. *International Journal of Innovative Research in Computer and Communication Engineering*, 9(12), 14705-14710.
48. **MATHEW, A. R. (2025).** Neurosecurity and Brain-Computer Interfaces.
49. **Soundappan, S. J. (2024).** AI-Driven Customer Intelligence in Enterprise Lakehouse Systems Sentiment Mining Governance-Aware Analytics and Real-Time Data Synchronization. *International Journal of Advanced Engineering Science and Information Technology (IJAESIT)*, 7(5), 14905.
50. **Mathew, A. (2025).** Human-AI Collaboration in Security Operations: Measuring Alert Trust, Automation Bias, and Analyst Upskilling in AI-Augmented SOC Environments. *International Journal of Computer Technology and Electronics Communication*, 8(5), 11375-11380.
51. **Soundappan, S. J. (2022).** AI-Based Fault Detection and Isolation for Reliability in Modern Power Systems. *International Journal of Research Publications in Engineering, Technology and Management (IRPETM)*, 5(4), 7106-7110.
52. **Poornima, G., & Anand, L. (2024, April).** Effective Machine Learning Methods for the Detection of Pulmonary Carcinoma. In *2024 Ninth International Conference on Science Technology Engineering and Mathematics (ICONSTEM)* (pp. 1-7). IEEE.
53. **Rengarajan, A., Jayakumar, C., & Sugumar, R. (2012).** Optimization Of Recent Attacks Using Internet Protocol. *National Journal of System and Information Technology*, 5(1), 8.
54. **Mathew, A. (2024).** AI TRiSM: Trust, Risk, and Security Management in Cybersecurity. *Cybersecurity*, 4(3), 84-90.
55. **Mathew, A. (2025).** Deep seek vs. ChatGPT: A deep dive into AI Language mastery. *Int J Multidisciplinary Res*, 7(1), 1-5.