



# Control of Hybrid System using Multi-Input Inverter and Maximum Power Point Tracking

Dr.S.Saravanan, Abishek P, Akash G, Anandhan V, Eswar K

Department of Electrical and Electronics Engineering, Muthayammal Engineering College, (Autonomous), Rasipuram,  
Tamil Nadu, India

**Publication History:** Received: 25.02.2026; Revised: 20.03.2026; Accepted: 25.03.2026; Published: 28.03.2026.

**ABSTRACT:** The objective of this project is to control the Wind/PV hybrid system using Multi-input inverter to get constant output power for different operating conditions. The MPPT also used in this system to get the maximum peak power to the load. The perturbation observation (P&O) method is used to accomplish the maximum power point tracking algorithm for input sources. The operational principle of the open loop and closed loop circuit of multi-input inverter is explained.

**KEYWORDS:** Inverter, photovoltaic (PV), wind energy.

## I. INTRODUCTION

The photovoltaic (PV) energy and wind energy applications have been increased significantly due to the rapid growth of power electronics techniques [1]–[3]. Generally, PV power and wind power are complementary since sunny days are usually calm and strong winds are often occurred at cloudy days or at night time. Hence, the hybrid PV/wind power system therefore has higher reliability to deliver continuous power than either individual source [4], [5]. But the size and components are made the system to complex and high cost.

Usually, two separated inverters for the PV array and the wind turbine are used for the hybrid PV/wind power system [7]. But in this project the multi-input inverter is combining with renewable energy sources in the dc end instead of the ac end. It can simplify the hybrid PV/wind power system and reduce the costs. This system used to get maximum constant power from hybrid system.

The multi-input inverter has the following advantages: 1) power from the PV array or the wind turbine can be delivered to the utility grid individually or simultaneously, 2) maximum power point tracking (MPPT) feature can be realized for both solar and wind energy, and 3) a large range of input voltage variation caused by different insolation and wind speed is acceptable.

## II. MULTI-INPUT INVERTER

The schematic diagram of the proposed multi-input inverter is shown in Fig. 1. It consists of a buck/buck-boost fused multi-input dc–dc converter and a full-bridge dc/ac inverter. The input dc voltage sources,  $V_{pv}$  and  $V_{wind}$  are obtained from the PV array and the rectified wind turbine output voltage. By applying the pulse-width-modulation (PWM) control scheme with appropriate MPPT algorithm to the power switches ( $M_1$ ) and ( $M_2$ ), the multi-input dc–dc converter can draw maximum power from both the PV array and the wind turbine individually or simultaneously. The dc bus voltage,  $V_{DC}$ , will be regulated by the dc/ac inverter with sinusoidal PWM (SPWM) control to achieve the input output power-flow balance. Details of the operation principle for the proposed multi-input inverter are introduced as follows.

### A. Hybrid system

In this project the wind/PV hybrid system is used to deliver continuous power to the load. The control of this hybrid system is obtained by Multi-input inverter and control circuits. MPPT algorithm (P&O method) also used to get maximum peak power to the load. The operations of PV only connected with multi-input inverter and Wind side only connected with multi-input inverter are used to get the power characteristics analysis of hybrid system.

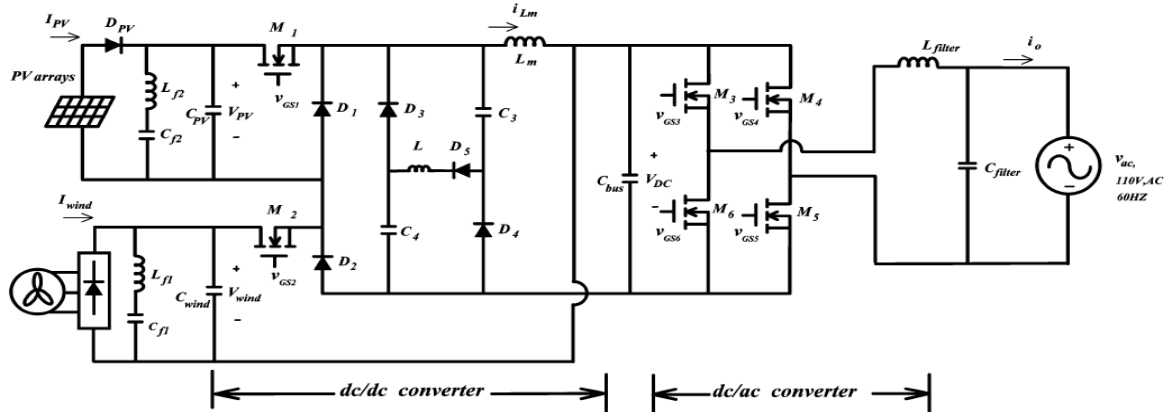

Fig 1: Schematic diagram of Multi-input inverter.

A (1). PV Array

The PV array is constructed by many series or parallel connected solar cells [8]. Each solar cell is form by a – junction semiconductor, which can produce currents by the photovoltaic effect. Typical output power characteristic curves for the PV array under different insolation are shown in Fig. 2. It can be seen that a maximum power point exists on each output power characteristic curve. Therefore, to utilize the maximum output power from the PV array, an appropriate control algorithm must be adopted.

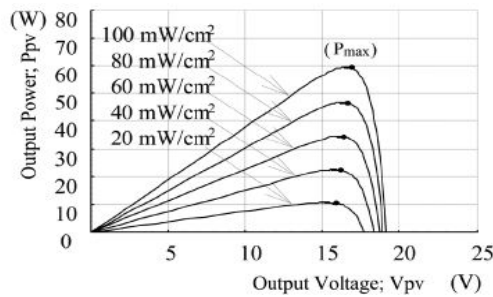

Fig.2. Typical output power characteristic curves of the PV array.

Fig. 3 shows the measured waveforms of gate driving signals, (Vgs1) of (M1) and (Vgs2) of (M2) , and inductor current . Because switches M1and M2 have different duty ratios, the inductor current has two different charging slopes. The multi-input dc–dc converter can deliver power from both of the two energy sources to the dc bus simultaneously. The measured waveforms of voltage, current, and power for the PV array and the wind turbine are shown in Fig. 4.

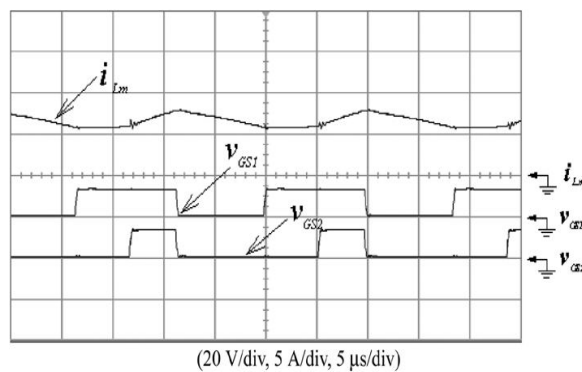

Fig 3: Gate signals Vgs1 & Vgs2 for M1 & M2 switches.



(2).Parameters of PV system  
 DC bus voltage (Vdc) = 230 V DC.  
 Switching Frequency (fs) = 50kHz , Switch (M1).  
 Power Factor = 0.99.  
 Total Harmonic distortion is less than 3%.

Only the PV array is connected to the proposed multi-input inverter. At the beginning, the controller will send out the PWM gate signal with MPPT feature to switch when the utility line voltage is detected. Once the dc bus voltage reaches its pre-set range, the dc/ac inverter will begin to inject ac output current into the utility line.

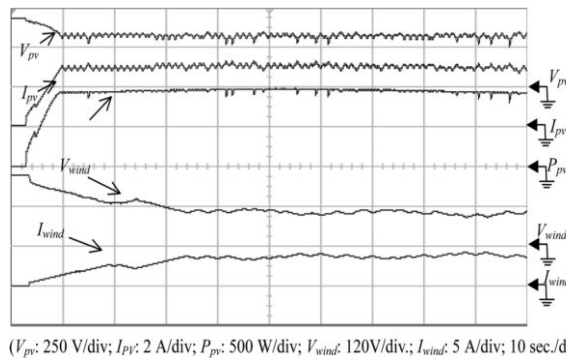

Fig .4.Measured waveforms of voltage, current, and power for the PV array and the wind turbine

B(1). Wind Turbine

Among various types of wind turbines, the permanent magnet synchronous wind turbine, which has higher reliability and efficiency, is preferred [13]–[16]. The power (Pwind) of the wind can be derived as

$$P_{wind} = \frac{1}{2} \rho A V_{wind}^3 \dots (1)$$

Where p is the air density (kg/m), A is the area (m) swept by wind blades, and Vwind is the wind speed (m/s). It had been proven that the energy conversion efficiency, Cp, of the wind turbine is a function of the tip speed ratio is defined as,

$$\lambda_{tip} = \frac{\omega r}{V_{wind}} \dots (2)$$

where w is the rotational speed (rad/sec) of wind turbine blades, r is the radius of the area swept by wind turbine blades.

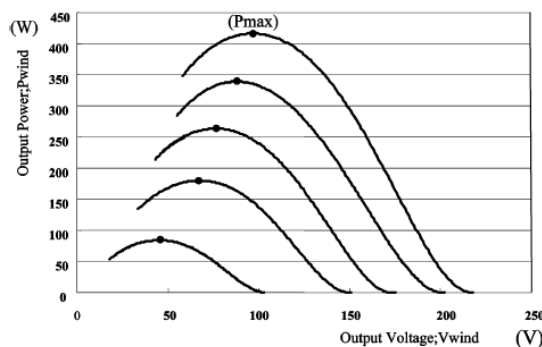

Fig5: Output power characteristic curves of the wind turbine for different wind speed.



When the output power of the wind turbine is small, the dc motor will request small power from the dc source to drive the wind turbine. When the output current of the wind turbine is increased, the output voltage and the rotational speed will be decreased. Also, the dc motor needs to provide a larger torque to the wind turbine. Since the dc motor has limited maximum input power predetermined by the control box, it can only provide limited maximum torque to the wind turbine which can only generate a limited maximum power to the load. Fig. 6 shows typical output power characteristic curves of the wind turbine under different driving power from the controllable dc motor. These curves have same characteristics with those driven by the natural air-stream. Each one of the curves represents a constant driving power from the dc motor. The output power of the wind turbine is drawn by an electronic load. The load current is gradually increased, and then the output power can be measured.

Output power characteristic curves shown in Fig.5. The P&O method is adopted as the MPPT algorithm for the wind turbine. Therefore, a power electronic converter with appropriate controller is needed. To process the wind energy which varies considerably according to the meteorological conditions such as wind speed.

(2).Wind parameters

Vwind =80 ~200 V DC.

Switching frequency =  
50kHz(M2),20kHz(M3,M6).

Power factor = 0.99.

THD =below 3.5%

C .Multi-input DC-DC Converter

The proposed multi-input dc–dc converter is the fusion of the buck-boost and the buck converter [17]. Syntheses of the multi-input dc–dc converter are done by inserting the pulsating voltage source of the buck converter into the buck-boost converter. In order not to hamper the normal operation of the buck-boost converter and to utilize the inductor for the buck converter, the pulsating voltage source of the buck converter must be series-connected with the output inductor. Base on the conduction status of the switches and , the multi-input dc–dc converter has four operation modes. Fig. 8(a)–(d) show the equivalent circuits for Mode I through Mode IV, respectively. When switches or are turned off, diodes and will provide a free-wheeling path for the inductor current. If one of the voltage sources is failed, the other voltage can still provide the electric energy, normally. Therefore, it is very suitable for renewable energy applications. Details of the circuit operation principle can be found in [17].

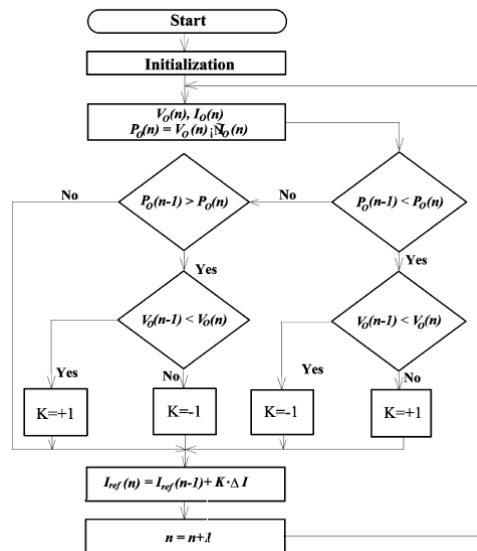

Fig 6: Flow chart of Maximum Power Point Tracking.

The input-output voltage relationship can be derived from the steady state volt-second balance analysis of the inductor. If has longer conduction time than has, then the equivalent operation circuit for one switching cycle will follow the sequence of Mode I, Mode III, and Mode IV. On the other hand,

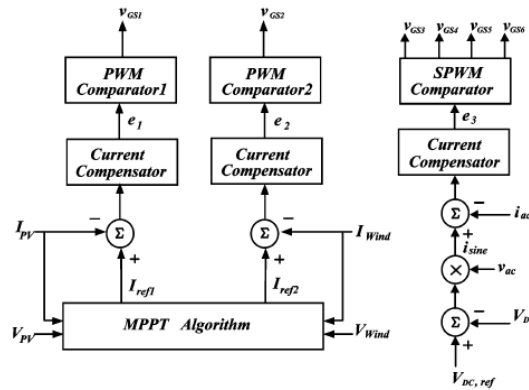

Fig.7. Control block diagram of the multi-input inverter.

if has longer conduction time than has, the sequence becomes Mode II, Mode III, and Mode IV. In either case, the output voltage can be expressed as,

$$V_{DC} = \frac{d_1}{1 - d_2} V_{PV} + \frac{d_2}{1 - d_2} V_{Wind} \quad \dots(3)$$

Where d1 and are d2 the duty ratio of switches M1 and M2 , respectively. Similarly, the average input and output current can be obtained

$$I_{PV} = \frac{d_1}{1 - d_2} I_o \quad \dots(4)$$

$$I_{Wind} = \frac{d_2}{1 - d_2} I_o \quad \dots(5)$$

From the above derived steady-state voltage and current equations, different power distribution demands of the multi-input dc–dc converter can be achieved.

(2).Output Parameters

Output Voltage (Vac) = 110V,60Hz.  
Output Power (Pmax) = 1kW.

(D). Control Scheme

The conceptual control block diagram of the proposed multi-input inverter is shown in Fig.7. The hardware implementation of the control circuit is realized by using a central control unit, digital signal processor (DSP) TMS320F240, and auxiliary analog circuits. The sensed voltage and current values for the PV array and the wind turbine are sent to the DSP where the MPPT algorithm will determine the reference current (Iref1) and (Iref2) for the PV array and the wind turbine. The PWM Comparator1 and Comparator2 will generate desired gate signals for power switches M1 and M2 according to the current error signals e1 and e2, respectively.

The dc/ac inverter will inject a sinusoidal current into the ac mains. The SPWM gate signals of switches M3 through M6 for producing sinusoidal ac current is generated by the DSP where the amplitude of the ac current is determined by the error signal of the measured dc bus voltage Vdc and Vdref. If the measured dc bus voltage is less than the reference value, then the amplitude of the ac output current will be decreased in order to increase the dc bus voltage. On

the contrary, if the dc bus voltage is higher than the reference one, then the amplitude of the ac output current will be decreased. On the other point of view, the dc bus voltage is regulated by the dc-ac inverter and the input-output power balance can be achieved.

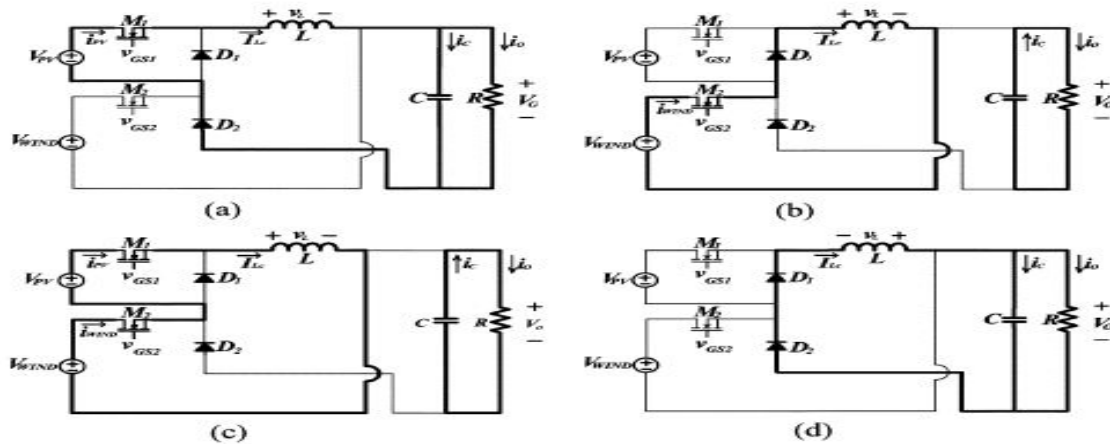

Fig.8. Equivalent circuits for the multi-input dc-dc converter (a) Mode I. (b) Mode II. (c) Mode III. (d) Mode IV.

### III. OPEN LOOP OF MULTI-INPUT INVERTER

The open loop control of multi input inverter is shown in fig 9. This system consist of one multi input DC-DC converter and DC-AC inverter. This converter is used to obtain maximum power from WIND/PV hybrid system. Inverter is used to regulate the dc bus voltage. This system is used to simplify the operation complexity and reduce the cost. The Output regulated voltage and current waveform of multi-input inverter is shown in fig 10.

#### SIMULATION DIAGRAM MODEL

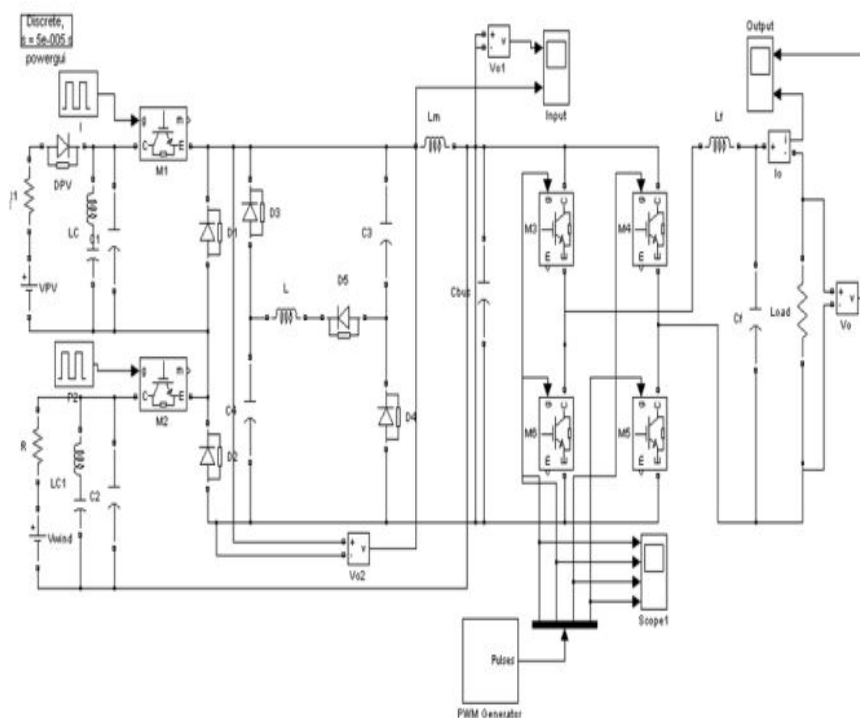

Fig9. Open loop circuit of multi-input inverter

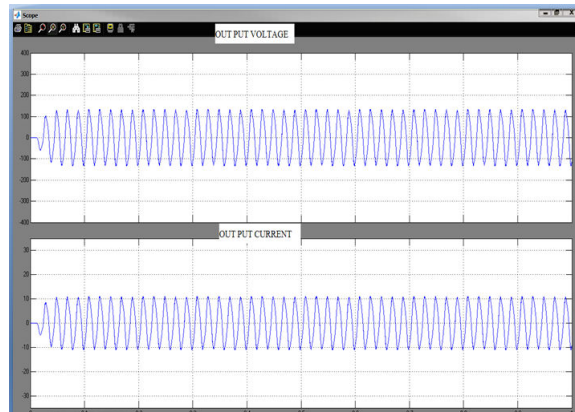

Fig10.Output voltage and current waveform of multi- input inverter.

#### IV .CLOSED LOOP OF MULTI-INPUT INVERTER

Fig 9 shows the maximum constant output power from the wind/PV hybrid system using Multi-input inverter and MPPT(P&O)method. This output current and voltages are for the particular predefined input values of voltages( $V_{in}$ ) and gate signals ( $V_{gs}$ ).

#### SIMULATION DIAGRAM MODEL

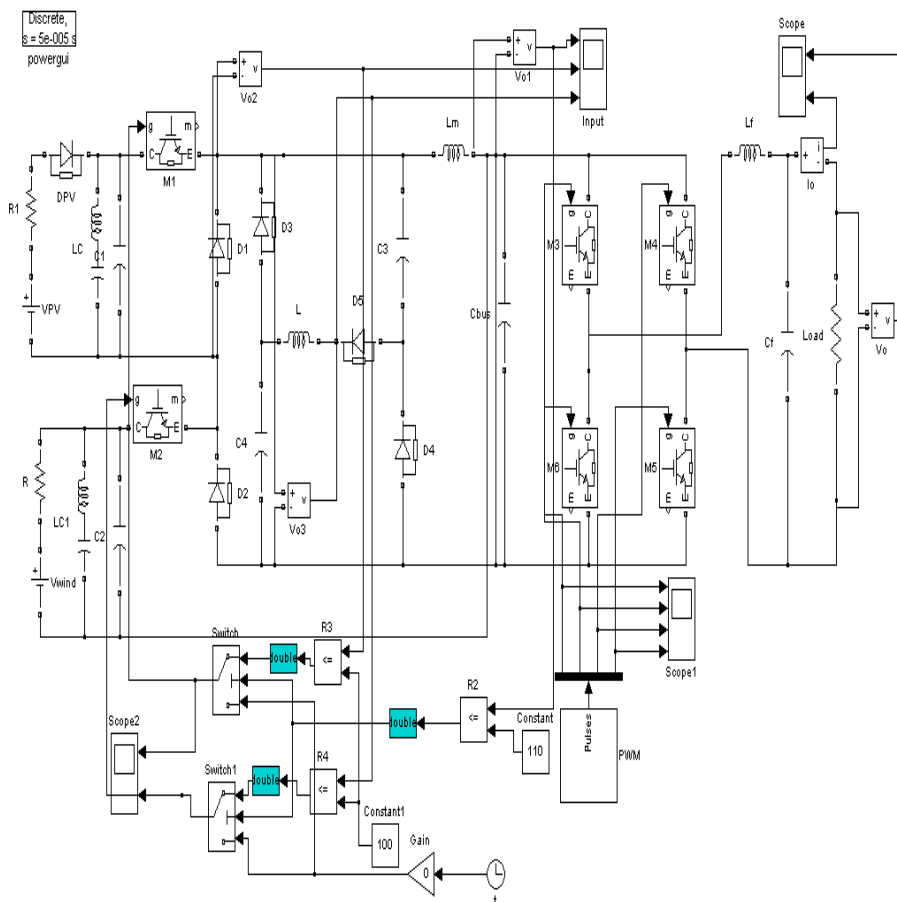

Fig.11 Closed loop operation of Multi-input inverter.

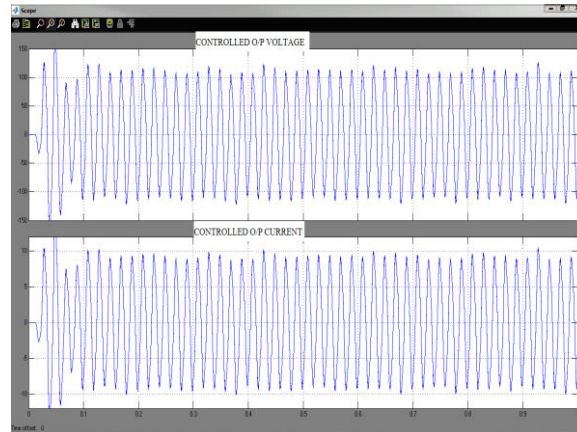

Fig.12 Output voltage and current waveform of multi-input inverter.

But in the closed loop of Multi-input inverter operation the maximum constant output power obtained for the different variable input conditions. This input and output balance controlled by using central control unit and DSP. So here no need of additional sensors.

## V. CONCLUSION

A multi-input inverter for the hybrid PV/wind power system is explained. Power from the PV array or the wind turbine can be delivered to the utility grid individually or simultaneously. MPPT feature can be realized for both PV and wind energy. A large range of input voltage variation caused by different insulation and wind speed is acceptable. The perturbation and observation method is adopted to realize the MPPT algorithm for the PV array and the wind turbine. simulation results for open loop operation shown in fig 10 to verify the performance of the multi-input inverter. The efficient control of Wind/PV system with closed loop operation of multi input inverter and simulation results for closed loop is shown in fig12 to verify the performance of the multi-input inverter and the maximum constant output power obtained for the different variable input conditions.

## REFERENCES

1. T.-F. Wu, C.-H. Chang, Z.-R. Liu, and T.-H. Yu, "Single-Stage converters for photovoltaic powered lighting systems with MPPT and charging features," in Proc. IEEE APEC, 1998, pp. 1149–1155.
2. M. Kolhe, J. C. Joshi, and D. P. Kothari, "Performance analysis of a directly Coupled photovoltaic water-pumping system," IEEE Trans. Energy Conv., vol. 19, no. 3, pp. 613–618, Sep. 2004.
3. A. M. De Broe, S. Drouilhet, and V. Gevorgian, "A peak power tracker for small wind turbines in battery charging applications," IEEE Trans. Energy Conv., vol. 14, no. 4, pp. 1630–1635, Dec. 1999.
4. C.Nagarajan and M.Madheswaran - 'Stability Analysis of Series Parallel Resonant Converter with Fuzzy Logic Controller Using State Space Techniques'- Taylor & Francis, Electric Power Components and Systems, Vol.39 (8), pp.780-793, May 2011. DOI: 10.1080/15325008.2010.541746
5. S.Thirunavukkarasu, C. Nagarajan, 2024, "Performance Investigation on OCF and SCF study in BLDC machine using FTANN Controller," Journal of Electrical Engineering And Technology, Volume 20, pages 2675–2688, (2025), doi.org/10.1007/s42835-024-02126-w
6. L. Solero, F. Caricchi, F. Crescimbeni,
7. O. Honorati, and F. Mezzetti, Performance of a 10 kW power electronic interface for combined wind/PV isolated generating systems," in Proc. IEEE PESC, 1996, pp. 1027–1032.
8. S. Wakao, R. Ando, H. Minami, F. Shinomiya, A. Suzuki, M. Yahagi, S. Hirota, Y. Ohhashi, and A. Ishii, "Performance analysis of the PV/wind/wave hybrid power generation system," in Proc. IEEE World Conf. Photovolt. Energy Conv., 2003, pp. 2337–2340.
9. B. S. Borowy and Z. M. Salameh, "Methodology for optimally sizing the combination of a battery bank and PV array in a wind/PV hybrid system," IEEE Trans. Energy Conv., vol. 11, no. 2, pp. 367–375, Jun. 1996.
10. S. B. Kjaer, J. K. Pedersen, and F. Blaabjerg, "A review of single-phase grid-connected inverters for photovoltaic modules," IEEE Trans. Ind. Appl., vol. 41, no. 5, pp. 1292–1306, Sep./Oct. 2005.



11. S. J. Chiang, K. T. Chang, and C. Y. Yen, "Residential photovoltaic energy storage system," *IEEE Trans. Ind. Electron.*, vol. 45, no. 3, pp. 385–394, Jun. 1998.
12. G. B. Shrestha and L. Goel, "A study on optimal sizing of stand-alone photovoltaic stations," *IEEE Trans. Energy Conv.*, vol. 13, no. 4, pp. 373–378, Dec. 1998.
13. J. H. R. Enslin and D. B. Snyman, "Combined low-cost, high-efficient inverter, peak power tracker and regulator for PV applications," *IEEE Tran. Power Electron.*, vol. 6, no. 1, pp. 73–82, Jan. 1991.
14. K. H. Hussein, I. Muta, T. Hoshino, and M. Osakada, "Maximum photovoltaic power tracking: An algorithm for rapidly changing atmospheric conditions," *Proc. Inst. Elect. Eng.*, vol. 142, no. 1, pp. 59–64, 1995.
15. C. Hua, J. Lin, and C. shen, "Implementation of a DSP-controlled photovoltaic system with peak power tracking," *IEEE Trans. Ind. Electron.*, vol. 45, no. 1, pp. 99–107, Feb. 1998.
16. O. F. Walker, *Wind Energy Technology*. New York: Wiley, 1997.
17. P. Gipe, *Wind Energy Comes of Age*. New York: Wiley, 1995.
18. K. Amei, Y. Takayasu, T. Ohji, and M. Sakui, "A maximum power control of wind generator system using a permanent magnet synchronous generator and a boost chopper circuit," in *Proc. Power Conv.*, 2002, vol. 3, pp. 1447–1452.
19. R. Cardenas, R. Pena, G. Asher, and J. Cilia, "Sensorless control of induction machines for wind energy applications," in *Proc. IEEE PESC*, 2002, pp. 265–270.
20. Y.-M. Chen, Y.-C. Liu, and S.-H. Lin, "Double Input PWM DC/DC converter for high/low voltage sources," in *Proc. IEEE Int. Telecommun. Energy Conf.*, 2003, pp. 27–32.
21. K. Prakashraj, G. Vijayakumar, S. Saravanan and S. Saranraj, "IoT Based Energy Monitoring and Management System for Smart Home Using Renewable Energy Resources," *International Research Journal of Engineering and Technology*, Vol.7, Issue 2, pp.1790-1797, 2020.
22. J Mohammed siddi, A. Senthil kumar, S. Saravanan, M. Swathisriranjani, "Hybrid Renewable Energy Sources for Power Quality Improvement with Intelligent Controller," *International Research Journal of Engineering and Technology*, Vol.7, Issue 2, pp.1782-1789, 2020.
23. T.R. Vignesh, M. Swathisriranjani, R. Sundar, S. Saravanan, T. Thenmozhi, "Controller for Charging Electric Vehicles Using Solar Energy", *Journal of Engineering Research and Application*, vol.10, Issue.01, pp.49-53, 2020.
24. G. Poovarasan, S. Susikumar, S. Naveen, N. Mohananthini, S. Saravanan, "Study of Poultry Fodder Passing Through Trolley in Feeder Box," *International Journal of Engineering Technology Research & Management*, vol.4, Issue.1, pp.76-83, 2020.
25. M. Revathi, S. Saravanan, R. Raja, P. Manikandan, "A Multiport System for A Battery Storage System Based on Modified Converter with MANFIS Algorithm," *International Journal of Engineering Technology Research & Management*, vol.4, issue 2, pp.217-222, 2020.
26. D Boopathi, S Saravanan, Kaliannan Jagatheesan, B Anand, "[Performance estimation of frequency regulation for a micro-grid power system using PSO-PID controller](#)", *International Journal of Applied Evolutionary Computation (IJAEC)*, Vol.12, Issue.4, pp.36-49, 2021.
27. V Kumarakrishnan, G Vijayakumar, D Boopathi, K Jagatheesan, S Saravanan, B Anand, "[Frequency regulation of interconnected power generating system using ant colony optimization technique tuned PID controller](#)", *Control and Measurement Applications for Smart Grid: Select Proceedings of SGESC 2021*, pp.129-141.
28. G Vijayakumar, M Sujith, S Saravanan, Dipesh B Pardeshi, MA Inayathullaa, "[An optimized MPPT method for PV system with fast convergence under rapidly changing of irradiation](#)", 2022 *International Virtual Conference on Power Engineering Computing and Control: Developments in Electric Vehicles and Energy Sector for Sustainable Future (PECCON)*, pp.1-4.
29. VM Geetha, S Saravanan, M Swathisriranjani, CS Satheesh, S Saranraj, "[Partial Power Processing Based Bidirectional Converter for Electric Vehicle Fast Charging Stations](#)", *Journal of Physics: Conference Series*, Vol.2325, Issue.1, pp.012028, 2022.
30. M Santhosh Kumar, G Dineshkumar, S Saravanan, M Swathisriranjani, M Selvakumari, "[Converter Design and Control of Grid Connected Hybrid Renewable Energy System Using Neuro Fuzzy Logic Model](#)", 2022 *Second International Conference on Computer Science, Engineering and Applications (ICCSEA)*, pp.1-6, 2022.
31. C Gnanavel, A Johny Renoald, S Saravanan, K Vanchinathan, P Sathishkhanna, "[An Experimental Investigation of Fuzzy-Based Voltage-Lift Multilevel Inverter Using Solar Photovoltaic Application](#)", *Smart Grids and Green Energy Systems*, pp.59-74, 2022.
32. V Kumarakrishnan, G Vijayakumar, D Boopathi, K Jagatheesan, S Saravanan, B Anand, "[Optimized PSO technique based PID controller for load frequency control of single area power system](#)", *Solid State Technology*, Vol.63, Issue.5, pp.7979-7990, 2020.



33. G. Poovarasan, S. Susikumar, S. Naveen, N. Mohananthini, S. Saravanan, "Implementation of IoT Based Poultry Feeder Box", International Journal of Innovative Research In Technology, Vol.6, Issue.2, pp.33-38, 2020.
34. N.Gokulnath, B.Jasim Khan, S.Kumaravel, Dr.A.Senthil Kumar and Dr.S.Saravanan, "Soldier Health and Position Tracking System", International Journal of Innovative Research In Technology, Vol-6 Issues 12, pp.39-45, 2020.
35. P.Navaneetha, R.Ramiya Devi, S.Vennila, P.Manikandan and Dr.S.Saravanan, " IOT Based Crop Protection System against Birds and Wild Animal Attacks", International Journal of Innovative Research In Technology, Vol-6 Issues 11, pp.133-143, 2020.
36. K. Punitha, M. Rajkumar, S. Karthick and Dr. S. Saravanan, " Impact of Solar And Wind Integration on Frequency Control System", International Research Journal of Engineering and Technology, Vol 7 Issue 3, pp.1357-1362,2020.
37. A.Arulkumar, S.Balaji, M.Balakrishnan, G.Dineshkumar and S.Saravanan, "Design And Implementation of Low Cost Automatic Wall Painting Machine" International Journal of Engineering Technology Research & Management, Vol-4 Issues 03, pp.170-176, 2020.
38. V.Periyasamy, S.Surya, K. Vasanth, Dr.G.Vijayakumar and Dr.S.Saravanan, "Design And Implementation of Iot Based Modern Weaving Loom Monitoring System" International Journal of Engineering Technology Research & Management, Vol-4 Issues 04, pp.11-18, 2020.
39. M.Yogheshwaran, D.Praveenkumar, S.Pravin, P.M.Manikandan and Dr.S.Saravanan, "IoT Based Intelligent Traffic Control System" International Journal of Engineering Technology Research & Management, Vol-4 Issues 04, pp.59-63, 2020.
40. R.Pradhap, R.Radhakrishnan, P.Vijayakumar, R.Raja and Dr.S.Saravanan, "Solar Powered Hybrid Charging Station For Electrical Vehicle" International Journal of Engineering Technology Research & Management, Vol-4 Issues 04, pp.19-27, 2020.
41. S.Shenbagavalli, T.Priyadharshini, S.Sowtharya, P.Manikandan and Dr.S.Saravanan, "Design and Implementation of Smart Traffic Controlling System" International Journal of Engineering Technology Research & Management, Vol-4 Issues 04, pp.28-36, 2020.
42. M.Pavithra, S.Pavithra, R.Rama Priya, M.Vaishnavee, M.Ranjitha and S.Saravanan, "Fingerprint Based Medical Information System Using IoT" International Journal of Engineering Technology Research & Management, Vol-4 Issues 04, pp.45-51, 2020.
43. A.Ananthan, A.M.Dhanesh, J.Gowtham, R.Dhinesh, G.Jeevitha and Dr.S.Saravanan, "IoT Based Clean Water Supply" International Journal of Engineering Technology Research & Management, Vol-4 Issues 03, pp.154-162, 2020.
44. R.Anbarsan, A.Arsathparvez, K.S.Arunachalam, M.Swathisriranjani and Dr.S.Saravanan, "Automatic Class Room Light Controlling Using Arduino" International Journal of Engineering Technology Research & Management, Vol-4 Issues 03, pp.192-201, 2020.
45. S.Karthikeyan, A.Krishnaraj, P.Magendran, T.Divya and Dr.S.Saravanan, "The Dairy Data Acquisition System" International Journal of Engineering Technology Research & Management, Vol-4 Issues 03, pp.163-169, 2020.
46. M.Amaran, S.Mannar Mannan, M.Madhu, Dr.R.Sagayaraj and Dr. S.Saravanan, "Design And Implementation of Low Cost Solar Based Meat Cutting Machine" International Journal of Engineering Technology Research & Management, Vol-4 Issues 03, pp.202-208, 2020.
47. N.Harish, R.Jayakumar, P.Kalaiyarasan, G.Vijayakumar and S. Saravanan, "IoT Based Smart Home Energy Meter" International Journal of Engineering Technology Research & Management, Vol-4 Issues 03, pp.177-183, 2020.
48. K.Subashchandrabose, G.Moulieshwaran, M.Raghul, V.Dhinesh and S.Saravanan, "Design of Portable Sanitary Napkin Vending Machine", International Journal of Engineering Technology Research & Management, Vol-4 Issues 03, pp.52-58, 2020.
49. D.Hemalatha, S.Indhumathi, V.Myvizhi and S.Saravanan, "Design and Implementation of Intelligent Controller for Domestic Applications", International Journal of New Innovations in Engineering and Technology, Vol.22, Issue.3, pp.4-7, 2023.
50. S. Divyasri, E. Indhu, M. P. Keerthana, M. Selvakumari and S. Saravanan, "Gas Cylinder Monitoring System using IoT", International Journal of New Innovations in Engineering and Technology, Vol.22, Issue.3, pp.67-71, 2023.
51. J.Arul, R.Balaji, S.Jeyamoorthy, M.Manipathra, R.Sundar and S.Saravanan, "IoT based Air Conditioner Control using ESP32", International Journal of New Innovations in Engineering and Technology, Vol.22, Issue.3, pp.48-52, 2023.
52. Vundel Munireddy, J.Prahathesvaran, C.R.Thirunavukarasu, M.Santhosh Kumar and S.Saravanan, "IoT Based Charge Controller for Direct Fast Charging of Electric Vehicles Using Solar Panel", International Journal of New Innovations in Engineering and Technology, Vol.22, Issue.3, pp.77-81, 2023.



53. D.Monish Kumar, K.Akash, S.Aswinkumar, S.Saravanan and R. Sagayaraj, "IoT based Industry Surveillance and Air Pollution Monitoring using Drones", International Journal of New Innovations in Engineering and Technology, Vol.22, Issue.3, pp.14-18, 2023.
54. T.Silambarasan, R.Surya, J.Pravinkumar, R.Sundar and S Saravanan, "IoT based Monitoring System For Sewage Sweeper", International Journal of New Innovations in Engineering and Technology, Vol.22, Issue.3, pp.88-93, 2023.
55. R.Aravinthan, Alwin.Augustin, P.Divagaran, S.Saravanan and P.Manikandan, "IoT Based Power Consumption and Monitoring System", International Journal of New Innovations in Engineering and Technology, Vol.22, Issue.3, pp.43-47, 2023.
56. S.Partheeban, S.Sundaravel, S.Umapathi, R.Sagayaraj and S.Saravanan, "IoT based Safety Helmet for Mining Workers", International Journal of New Innovations in Engineering and Technology, Vol.22, Issue.3, pp.116-120, 2023.
57. K.Eswaramoorthi, R.Manikandan, R.Balamurugan, C.Ramkumar and S.Saravanan, "Smart Parking System using IoT", International Journal of New Innovations in Engineering and Technology, Vol.22, Issue.3, pp.53-57, 2023.
58. S.Nirmalraj, C.Pranavan, M.Prem and S.Saravanan, "Smart Trolley With IoT Based Billing System", International Journal of New Innovations in Engineering and Technology, Vol.22, Issue.3, pp.111-115, 2023.
59. V.Gunasekaran, M.Gowtham, S. Anubalaji, S.Saravanan and R.Prakash, "Solar based Electric Wheel Chair", International Journal of New Innovations in Engineering and Technology, Vol.22, Issue.3, pp.8-13, 2023.
60. P Thava Prakash, P.Venketesan, D.Vignesh, S.Prakash, S.Saravanan, "Design of Low Cost E-Bicycle using Brushless DC Motor with Speed Regulator", International Journal of New Innovations in Engineering and Technology, Vol.22, Issue.3, pp.148-153, 2023.
61. D.Tamilarasan, V.S.Vairamuthu, Y.Vasanth, K.Umadevi, S.Saravanan, "GSM based Agricultural Motor Control", International Journal of New Innovations in Engineering and Technology, Vol.22, Issue.3, pp.172-177, 2023.
62. P. Vimal, S.Veerasingamani, R.Srihari, C.S.Satheesh, S.Saravanan, "IoT Based Optimal Power Management System For Smart Grid", International Journal of New Innovations in Engineering and Technology, Vol.22, Issue.3, pp.160-165, 2023.
63. S.Abimanyu, P.Jagadheeswaran, S.Jaganath, K.Sanjay, R.Sivapranesh, K.Velmurugan, N.Mohananthini, C.S.Satheesh, S.Saravanan, "Portable Solar Tree", International Journal of New Innovations in Engineering and Technology, Vol.22, Issue.3, pp.154-159, 2023.
64. M.Karthikeyan, S.Bilalahamad, V.A.Chandru, V.Deepika and S.Saravanan, "Design and Development of IoT based Motor Starter", International Journal of New Innovations in Engineering and Technology, Vol.22, Issue.3, pp.178-183, 2023.
65. R.Anbarsan, A.Arsathparvez, K.S.Arunachalam, M.Swathisriranjani and S.Saravanan, "Automatic Class Room Light Controlling Using Arduino" International Journal of Engineering Technology Research & Management (IJETRM), Vol-4 Issues 03, pp.192-201, 2020.
66. S.Karthikeyan, A.Krishnaraj, P.Magendran, T.Divya and S.Saravanan, "The Dairy Data Acquisition System" International Journal of Engineering Technology Research & Management (IJETRM), Vol-4 Issues 03, pp.163-169, 2020.
67. N.Harish, R.Jayakumar, P.Kalaiyarsan, G.Vijayakumar and S. Saravanan, "IoT Based Smart Home Energy Meter" International Journal of Engineering Technology Research & Management (IJETRM), Vol-4 Issues 03, pp.177-183, 2020.
68. G. Poovarasan, S. Susikumar, S. Naveen, N. Mohananthini, S. Saravanan, "Study of Poultry Fodder Passing Through Trolley in Feeder Box," International Journal of Engineering Technology Research & Management, vol.4, Issue.1, pp.76-83, 2020.
69. A.Ananthan, A.M.Dhanesh, J.Gowtham, R.Dhinesh, G.Jeevitha and S.Saravanan, "IoT Based Clean Water Supply" International Journal of Engineering Technology Research & Management (IJETRM), Vol-4 Issues 03, pp.154-162, 2020.
70. Ram Kumar C, Saravanan S, and Nagarajan C, "Hybrid LSTM and Deep Reinforcement Learning for Autonomous Battery Health Optimization in Electric Vehicles", Electrical Power Systems Research, Vol-253 Issues 112535, ISSN No:0378-7796,2025.
71. Gopinathan, V. R. (2024). Real-Time Fault-Tolerant Multi-Cloud Database Architectures for High Availability Applications. International Journal of Future Innovative Science and Technology (IJFIST), 7(4), 13148.
72. Chandra, S., Rengarajan, A., Sahoo, G. S., & Sharma, S. (2023, December). Identifying Neuronal Damage and Plasticity by Analyzing Changes in Diffusion Tensor Imaging. In International Conference on Data Science, Machine Learning and Applications (pp. 433-438). Singapore: Springer Nature Singapore.



73. Sugumar, R. (2025). Federated AI in Offline-First Mobile Health Architectures for Privacy-Preserving Clinical Intelligence. *International Journal of Science, Research and Technology*, 8(4), 14589-14600.
74. Murugeswari, B., Rajalakshmi, S., & Sudharson, K. (2023). Hybrid Approach for Privacy Enhancement in Data Mining Using Arbitrariness and Perturbation. *Computer Systems Science & Engineering*, 44(3).
75. Pandey, V. K., Mishra, S., Rengarajan, A., Savita, & Roomi, M. M. (2024, March). Enhancing Weather Forecasting with Machine Learning Techniques. In *International Conference on Renewable Power* (pp. 147-156). Singapore: Springer Nature Singapore.
76. Soundappan, S. J. (2025). Next Generation AI Enabled Holistic Cognitive Platform for Secure Cloud Network Intelligence Enterprise Systems and Digital Trust Optimization. *International Journal of Computer Technology and Electronics Communication*, 8(5), 11534-11542.
77. Mathew, A. (2022). Leveraging Big Data Analytics to Power AI and ML (Machine Learning) Automation. *Educational Research (IJMCIER)*, 4(5), 131-134.
78. Sugumar, R. (2024). AI-Augmented Quality Engineering for Performance Optimization and Test Orchestration in Distributed Systems. *International Journal of Science, Research and Technology*, 7(5), 12835-12846.
79. Akila, R. (2024). A deep reinforcement learning approach for optimizing inventory management in the agri-food supply chain. *J. Electrical Systems*, 20(4s), 2238-2247.
80. Mahendran, M., Anbazhagan, K., Pavithran, G., Nivas, A., & Pandey, S. D. (2022). Earthquake Damage Prediction using Machine Learning. *Grenze International Journal of Engineering & Technology (GIJET)*, 8(1).
81. Gopinathan, V. R. (2025). Enterprise AI Frameworks for Financial Data Engineering Behavioural Analytics and Intelligent Cloud Solutions. *International Journal of Research Publications in Engineering, Technology and Management (IJRPETM)*, 8(4), 12499-12506.
82. Kondalsamy, P., & Kaliappan, K. (2025). An Optimal Prediction of Leaf Disease Based on Hybrid Deep Learnings and Metaheuristic Technique. *Traitement du Signal*, 42(1), 363.
83. Deivendran, P., Babu, P. S., Malathi, G., Anbazhagan, K., & Kumar, R. S. (2023). Emotion Recognition for Challenged People Facial Appearance in Social using Neural Network. *arXiv preprint arXiv:2305.06842*.
84. Sugumar, R. (2025). Unified AI Framework for Predictive Data Engineering and Real Time Prescription and Billing Systems. *International Journal of Advanced Engineering Science and Information Technology (IAESIT)*, 8(5), 17261.
85. Vekariya, V., Kumar, S., & Rengarajan, A. (2024). A distinctive and smart agricultural knowledge-based framework using ontology. In *Sustainability in Digital Transformation Era: Driving Innovative & Growth* (pp. 207-213). CRC Press.
86. Gopinathan, V. R. (2025). Software engineering practices for AI-driven systems: From development to deployment (MLOps perspective). *International Journal of Science, Research and Technology*, 8(1), 13493-13500.
87. Mathew, A. R. (2022). Threats and protection on E-sim: a prospective study. *Novel Perspectives of Engineering Research*, 8, 76-81.
88. Naveena, S., & Kavitha, K. (2025). Gossypium herbaceum: Folium disease identification and classification using Efficient Net-Coordinate Convolutional Neural Network (EcoNet). *Engineering Applications of Artificial Intelligence*, 152, 110701.
89. Rengarajan, A., Mishra, A., Kulhar, K. S., Shrivastava, V. P., & Alawneh, Y. J. J. (2024, March). Role of Deep Reinforcement Learning in Mitigating Cyber Security Issues: A Review. In *International Conference on Renewable Power* (pp. 37-48). Singapore: Springer Nature Singapore.
90. Achari, A. P. S. K., & Sugumar, R. (2024, November). Performance analysis and determination of accuracy using machine learning techniques for naive bayes and random forest. In *AIP Conference Proceedings* (Vol. 3193, No. 1, p. 020199). AIP Publishing LLC.
91. Mathew, A., & Alex, H. (2022). Detect & protect-medical device cybersecurity. *Curr. Overview Sci. Technol. Res*, 1, 60-68.
92. Sammy, F., Chettier, T., Boyina, V., Shingne, H., Saluja, K., Mali, M., ... & Shobana, A. (2025). Deep Learning-Driven Visual Analytics Framework for Next-Generation Environmental Monitoring. *Journal of Applied Science and Technology Trends*, 114-122.
93. Anbazhagan, K. (2024). Trustworthy and Adaptive AI Systems for Enterprise Analytics Cybersecurity and Decision Optimization Using API-First and Cloud-Native Architectures. *International Journal of Technology, Management and Humanities*, 10(03), 65-74.
94. Mathew, A. (2021). Deep reinforcement learning for cybersecurity applications. *Int J Comput Sci Mob Compu*, 10(12), 32-38.
95. Dhinakaran, D. (2022). Joe Prathap P. M, Selvaraj D, Arul Kumar D and Murugeswari B," Mining Privacy-Preserving Association Rules based on Parallel Processing in Cloud Computing,". *International Journal of Engineering Trends and Technology*, 70(3), 284-294.



96. Karthika, K., Anusha, K., Kavitha, K., Harshadha, R., Dharshini, D. S., & Sundhar, N. A. (2025, April). Frequency Reconfigurable Antenna using Advanced Materials: A Study. In 2025 3rd International Conference on Advancements in Electrical, Electronics, Communication, Computing and Automation (ICAECA) (pp. 1-6). IEEE.
97. Thavamani, C., & Rengarajan, A. (2024). Clustering related behaviour of users by the use of partitioning and parallel transaction reduction algorithm. *International Journal of Advanced Intelligence Paradigms*, 29(2-3), 122-132.
98. Sugumar, R. (2025). Unified AI Framework for Predictive Data Engineering and Real Time Prescription and Billing Systems. *International Journal of Advanced Engineering Science and Information Technology (IAESIT)*, 8(5), 17261.
99. Soundappan, S. J., & Sugumar, R. (2016). Optimal knowledge extraction technique based on hybridisation of improved artificial bee colony algorithm and cuckoo search algorithm. *International Journal of Business Intelligence and Data Mining*, 11(4), 338-356.
100. SakthiPreetha, A., Kavitha, K., Karthika, K., & Manohari, R. G. (2025, April). A Novel Metasurface-Embedded Antenna for WBAN Communications. In 2025 3rd International Conference on Advancements in Electrical, Electronics, Communication, Computing and Automation (ICAECA) (pp. 1-4). IEEE.
101. Murugeswari, B., Selvaraj, D., Sudharson, K., & Radhika, S. (2023). Data Mining with Privacy Protection Using Precise Elliptical Curve Cryptography. *Intelligent Automation & Soft Computing*, 35(1).
102. Gopinathan, V. R. (2025). Software engineering practices for AI-driven systems: From development to deployment (MLOps perspective). *International Journal of Science, Research and Technology*, 8(1), 13493-13500.
103. Anbazhagan, K., Kumar, R., Thilagavathy, R., & Anuradha, D. (2024, March). Shortest Job First with Gateway-based Resource Management Strategy for Fog Enabled Cloud Computing. In 2024 4th International Conference on Data Engineering and Communication Systems (ICDECS) (pp. 1-6). IEEE.
104. Kannadhasan, S., Vasuki, S., Kavitha, K., Karthikeyan, P., & Usha, S. G. A. (Eds.). (2025, April). Preface: Role of Artificial Intelligence and IoT in Engineering, Technology & Science [ICRAETS 2024]. In *AIP Conference Proceedings* (Vol. 3258, No. 1, p. 010001). AIP Publishing LLC.
105. Dhinakaran, D., Prathap, P. J., Selvaraj, D., Kumar, D. A., & Murugeswari, B. (2022). Mining privacy-preserving association rules based on parallel processing in cloud computing. *International Journal of Engineering Trends and Technology*, 70(3), 284-294.