



Transformerless High Step-up DC-DC Converter with Reduced Ripple Content using COCKCROFT WALTON Voltage Multiplier

Dr.R.Raja, Bhuvanbharath K, Darshan G, Gopinatha A, Karthik M S

Department of Electrical and Electronics Engineering, Muthayammal Engineering College (Autonomous), Rasipuram, Tamil Nadu, India

Publication History: Received: 25.02.2026; Revised: 20.03.2026; Accepted: 25.03.2026; Published: 28.03.2026.

ABSTRACT: A high step up DC-DC converter based on Cockcroft Walton voltage multiplier without a line or high frequency step up transformer .It provides continuous input current with low ripple, high voltage ratio and low voltage stress on the switches, diodes and capacitor The converter is quite suitable for low input level dc generation systems. Based on n-stage Cockcroft Walton voltage multiplier sliding mode control strategy is employed to reduce the ripple content. The proposed converter provides a suitable dc source for n+1 level multilevel inverter. The output voltage of the converter is regulated at 450V for n= 3 stages of Cockcroft Walton voltage multiplier.

KEYWORDS: Cockcroft Walton voltage multiplier, High voltage ratio , Multilevel inverter, step-up dc-dc converter .

I. INTRODUCTION

Researchers and Governments worldwide have made efforts on renewable energy applications for mitigating natural energy consumption and environmental concerns the photo voltaic (PV) cell and fuel cell have been considered attractive choices. However, without extra arrangements, the output voltages generated from both of them are with rather low level. Thus a high step-up dc- dc converter is desired in the power conversion systems corresponding to these two energy sources.

A high step-up dc- dc converter is also required by many industrial applications, such as high intensity discharge lamp ballasts for automobile head lamps and battery backup systems for uninterruptible power supplies, the conventional boost dc-dc converter can provide a very high voltage gain by using an extreme high duty cycle. However, practically parasitical elements associated with the inductor, capacitor, switch and diode cannot be ignored regarding their effects reduce the theoretical voltage gain.

Many step-up dc-dc converter has been proposed to obtain high voltage ratios without extreme high duty cycle by using isolated transformers or coupled inductors. Among these the voltage fed type dc-dc converters sustains high input current ripple. Thus providing low input current ripple and high voltage ratio. Current fed converters are generally superior to voltage fed converters. However, in order to achieve high voltage gain the leakage inductance of the transformers is relatively increased due to high number of winding turns. Consequently the switch is burdened with high voltage spikes across the switch at the turn off instant. Thus higher voltage rating switches are required. The design of high frequency transformers, coupled inductors or resonant components for these converters is relatively complex.

Alternative step-up dc-dc converters without step-up transformers and coupled inductors where utilized. Moreover cascading diode- capacitor or diode-inductor modules, these kind of dc-dc converters provide not only high voltage gain but also simple and robust structures. The control methods for conventional dc-dc converters can easily adapt to them, for most of these cascaded structures the voltage stress on each individual switch and passive elements depends on the number of stages.

A conventional boost converter and an n-stage diode-capacitor multiplier has the merit that higher voltage gain can easily be obtained by adding the stages of the diode-capacitor multipliers without modifying the main switch circuit. In past few decades, high voltage dc power supplies have been widely applied to industries, science, medicine, military and especially in test equipment such as X-ray systems, dust filtering insulating test and electrostatic coating providing

the advantages of high voltage ratio, low voltage stress on the diodes and capacitors, compactness and cost efficiency the conventional Cockcroft-Walton (CW) voltage multiplier is very popular among high voltage dc applications. However the major drawback is that a high ripple voltage appears at the output when low frequency (50 or 60 Hz) utility sources used. This paper proposes a high step-up dc-dc converter based on CW voltage multiplier replacing the step-up transformer with the boost type structure. Thus the proposed converter is suitable for power conversion applications where high voltage gains are desired.

II. DC-DC CONVERTER BASED ON CW VOLTAGE MULTIPLIER

A. Constructional Features

Multilevel inverters are in general uses high frequency switches to be The converter deploys four switches S_{c1} and S_{c2} are used to generate an Alternating source to feed into the CW voltage multiplier and S_{m1} and S_{m2} are used to control the inductor energy to obtain a boost performance. The four switches operate at two independent frequencies, which provide coordination between output ripple and system efficiency.

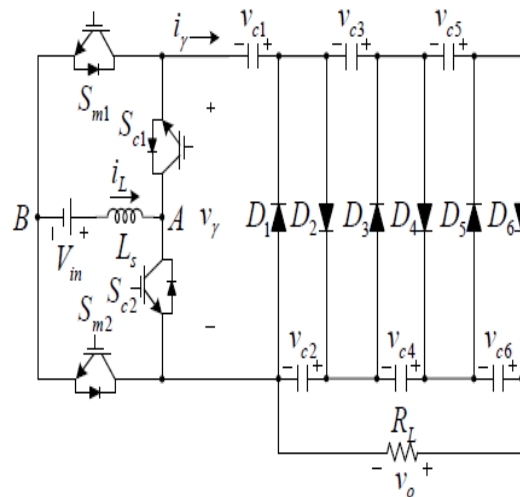

Fig. 1 Circuit diagram for 3 stage CW voltage multiplier

The 3 stage CW voltage multiplier is supplied by a low level dc source, such as battery, PV module or fuel cell sources. The converter consist of one boost inductor L_s , four switches (S_{c1} , S_{c2} and S_{m1}, S_{m2}), and one n-stage CW voltage multiplier. S_{m1} (S_{c1}) and S_{m2} (S_{c2}) operate in complementary mode, and the operating frequencies of S_{m1} (S_{c1}) are defined as f_{sm} denoted as modulation frequency, f_{sc} denoted as alternating frequency. Theoretically these two frequencies should be as high as possible, so that smaller inductor and capacitors can be used in the circuit. f_{sm} is set much higher than f_{sc} , and the output voltage is regulated controlling the duty cycle of S_{m1} and S_{m2} , while the output voltage ripple can be adjusted by f_{sc} . The well known CW voltage multiplier is constructed by a cascade of stages with each stage containing two capacitors and two diodes. In an n-stage CW voltage multiplier, there are $N(=2n)$ capacitors and N diodes. For convenience, both capacitors and diodes are divided into odd group and even group.

B. Circuit operation

- 1) The three stage CW voltage multiplier circuit elements are assumed to be ideal and there is no power loss in the system.
- 2) When a high frequency periodic alternating current is fed into the CW circuit and all of the capacitors in the CW voltage multiplier are sufficiently large, the voltage drop and ripple of each capacitor voltage can be ignored under a reasonable load conditions. Thus the voltages across all the capacitors are equal, except the first capacitor which voltage is one half of the others.
- 3) The proposed converter is operating in continuous conduction mode and in the steady state conditions.
- 4) When the inductor transfers the storage energy to the CW circuit, only one of the diodes in CW circuit will be conducted.
- 5) Some safe commutation states are ignored.

For an n-stage CW voltage multiplier, the output voltage is equal to the total voltage of all even capacitors.

Under steady state conditions the voltage gain of the converter is given by

$$Mv = V_o / V_{in} = 2n / (1-D)$$

where Mv = Static voltage gain, n = number of stages, D = Duty cycle

III. PROPOSED CONTROL STRATEGY FOR HIGH STEP-UP DC-DC CONVERTER USING CW VOLTAGE MULTIPLIER

A. Sliding mode control strategy

It is a non linear control method that alters the dynamics of a non linear system by application of discontinuous control signal that forces the system to slide along a cross section of the systems normal behavior.

The state feedback control law is not a continuous function of time. Instead, it can switch from one continuous structure to another based on the current position in the state space.

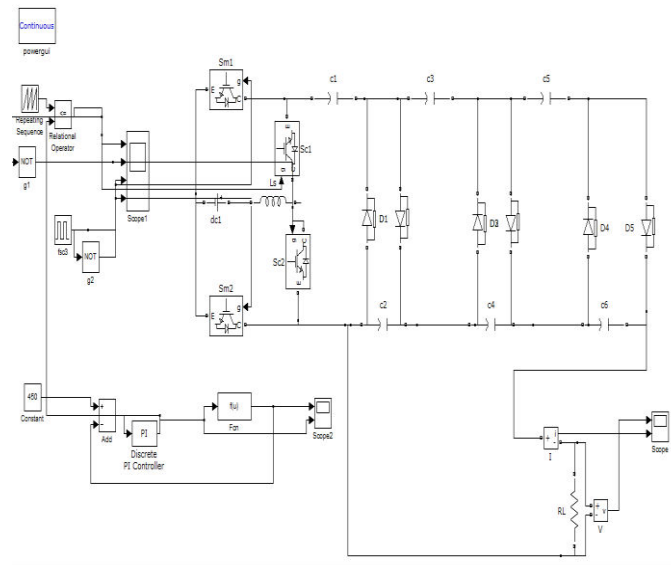

Fig. 2 Simulation diagram of Converter using sliding mode control

Hence sliding mode control is a variable structure control method. The multiple control structures are designed so that trajectories always move towards an adjacent region with a different control structure, and so the ultimate trajectory will not exist entirely within one control structure. Instead it will slide along the boundaries of the control structure.

The motion of the system as it slides along the boundaries is called a sliding mode and the geometrical locus consisting of the boundaries is called the sliding hyper surface. In the context of modern control theory, any variable structure system like a system under SMC (Sliding mode control) may be viewed as a special case of a hybrid dynamical system, as the system both flows through a continuous state space but also moves through different discrete control modes.

Sliding mode control scheme involves

- 1) Selection of a hyper surface or manifold (Sliding surface – The system trajectory exhibits desirable behaviour when confined to this manifold)
- 2) Finding feedback gain so that the system trajectory intersects and stays on the manifold.

IV. SIMULATION RESULTS

The Simulation diagram shown in figure 2 represents the proposed control strategy using Sliding mode control (SMC). Sc_1 and Sc_2 are used to generate the alternating voltage, Sm_1 and Sm_2 are used to control the inductor energy to obtain a boost performance. By sliding mode control fast dynamic response, improved performance and reduction in ripple content is obtained

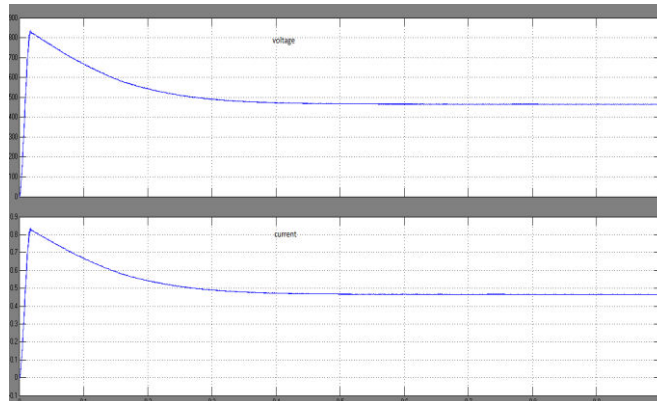

Fig. 3 Simulated Output Voltage & Current waveform using SMC control

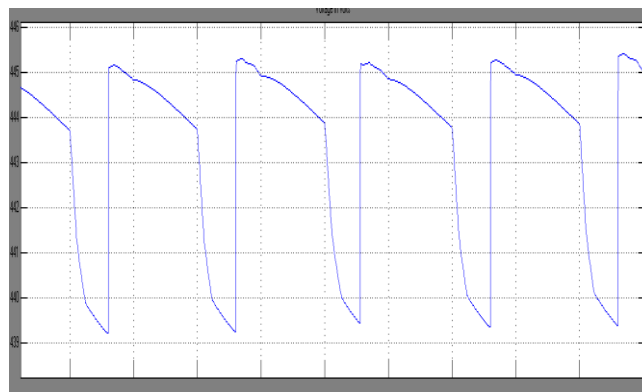

Fig. 4 Output Voltage ripple using existing Average current limit control

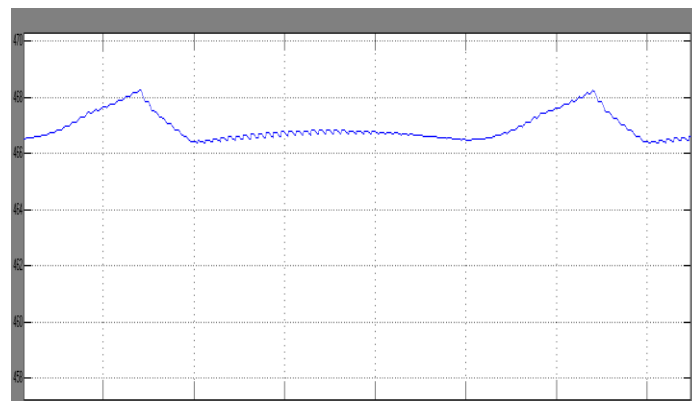

Fig. 5 Reduced ripple voltage obtained employing by sliding mode control

The system specifications for input dc voltage $V_{in} = 54V$ and modulation frequency $f_{sm} = 60$ KHz and $f_{sc} = 1$ KHz with resistive load = $1K\Omega$ for $n = 3$ stages have been furnished in figure 2 and the resulting waveforms can be referred in figure 3.

Figure 4 and 5 represent the ripple voltages employing Average current limit control and Sliding mode control respectively.



V. CONCLUSION

In this paper a high step-up dc-dc converter based on CW voltage multiplier without a line or high frequency stepup transformer was presented to obtain a high voltage gain. Since the voltage stress on the active switches, diodes and capacitors is not affected by the number of cascaded stages, power components with same voltage ratings can be selected. The proposed converter provides high voltage gain with improved performance and fast response with reduced ripple content. The simulation results has proved the feasibility of the proposed control strategy employed.

REFERENCES

1. B. K. Bose, "Energy, environment, and advances in power electronics," IEEE Trans. Power Electron., vol. 15, no. 4, pp. 688–701, Jul. 2000.
2. Q. Li and P. Wolfs, "A review of the single phase photovoltaic module integrated converter topologies with three different DC link configurations," IEEE Trans. Power Electron., vol. 23, no. 3, pp. 1320–1333, May 2008.
3. W. Li and X. He, "Review of Nonisolated high-step-up DC/DC converters in photovoltaic grid-connected applications," IEEE Trans. Ind. Electron., vol. 58, no. 4, pp. 1239–1250, Apr. 2011
4. G. R. Walker and P. C. Sernia, "Cascaded DC-DC converter connection of photovoltaic modules," IEEE Trans. Power Electron., vol. 19, no. 4, pp. 1130–1139, Jul. 2004.
5. J. Wang, F. Z. Peng, J. Anderson, A. Joseph, and R. Buffenbarger, "Low cost fuel cell converter system for residential power generation," IEEE Trans. Power Electron., vol. 19, no. 5, pp. 1315–1322, Sept. 2004.
6. C.Nagarajan and M.Madheswaran - 'Stability Analysis of Series Parallel Resonant Converter with Fuzzy Logic Controller Using State Space Techniques'- Taylor & Francis, Electric Power Components and Systems, Vol.39 (8), pp.780-793, May 2011. DOI: 10.1080/15325008.2010.541746
7. S.Thirunavukkarasu, C. Nagarajan, 2024, "Performance Investigation on OCF and SCF study in BLDC machine using FTANN Controller," Journal of Electrical Engineering And Technology, Volume 20, pages 2675–2688, (2025), doi.org/10.1007/s42835-024-02126-w
8. R. J. Wai, C. Y. Lin, C. Y. Lin, R. Y. Duan, and Y. R. Chang, "High-efficiency power conversion system for kilowatt-level stand-alone generation unit with low input voltage," IEEE Trans. Ind. Electron., vol. 55, no. 10, pp. 3702–3714, Oct. 2008.
9. J. M. Kwon, E. H. Kim, B. H. Kwon, and K. H. Nam, "High-efficiency fuel cell power conditioning system with input current ripple reduction," IEEE Trans. Ind. Electron., vol. 56, no. 3, pp. 826–834, Mar. 2009.
10. A. K. Rathore, A. K. S. Bhat, and R. Oruganti, "Analysis, design and experimental results of wide range ZVS active-clamped L-L type current-fed DC/DC converter for fuel cells to utility interface," IEEE Trans. Ind. Electron., vol. 59, no. 1, pp. 473–485, Jan. 2012.
11. B. Yuan, X. Yang, X. Zeng, J. Duan, J. Zhai, and D. Li, "Analysis and design of a high step-up current-fed multiresonant DC/DC converter with low circulating energy and zero-current switching for all active switches," IEEE Trans. Ind. Electron., vol. 59, no. 2, pp. 964–978, Feb. 2012.
12. T. F. Wu, Y. S. Lai, J. C. Hung, and Y. M. Chen, "Boost converter with coupled inductors and buck-boost type of active clamp," IEEE Trans. Ind. Electron., vol. 55, no. 1, pp. 154–162, Jan. 2008.
13. S. S. Lee, S. W. Rhee, and G. W. Moon, "Coupled inductor incorporated boost half-bridge converter with wide ZVS operation range," IEEE Trans. Ind. Electron., vol. 56, no. 7, pp. 2505–2512, Jul. 2009.
14. K.Prakashraj, G.Vijayakumar, S.Saravanan and S.Saranraj, "IoT Based Energy Monitoring and Management System for Smart Home Using Renewable Energy Resources," International Research Journal of Engineering and Technology, Vol.7, Issue 2, pp.1790-1797, 2020.
15. J Mohammed siddi, A. Senthil kumar, S.Saravanan, M. Swathisriranjani, "Hybrid Renewable Energy Sources for Power Quality Improvement with Intelligent Controller," International Research Journal of Engineering and Technology, Vol.7, Issue 2, pp.1782-1789, 2020.
16. T.R. Vignesh, M.Swathisriranjani, R.Sundar, S.Saravanan, T.Thenmozhi, "Controller for Charging Electric Vehicles Using Solar Energy", Journal of Engineering Research and Application, vol.10, Issue.01, pp.49-53, 2020.
17. G. Poovarasana, S. Susikumar, S. Naveen, N. Mohananthini, S. Saravanan, "Study of Poultry Fodder Passing Through Trolley in Feeder Box," International Journal of Engineering Technology Research & Management, vol.4, Issue.1, pp.76-83, 2020.
18. M.Revathi, S.Saravanan, R.Raja, P.Manikandan, "A Multiport System for A Battery Storage System Based on Modified Converter with MANFIS Algorithm," International Journal of Engineering Technology Research & Management, vol.4, issue 2, pp.217-222, 2020.



19. D Boopathi, S Saravanan, Kaliannan Jagatheesan, B Anand, "[Performance estimation of frequency regulation for a micro-grid power system using PSO-PID controller](#)", International Journal of Applied Evolutionary Computation (IJAEC), Vol.12, Issue.4, pp.36-49, 2021.
20. V Kumarakrishnan, G Vijayakumar, D Boopathi, K Jagatheesan, S Saravanan, B Anand," [Frequency regulation of interconnected power generating system using ant colony optimization technique tuned PID controller](#)", Control and Measurement Applications for Smart Grid: Select Proceedings of SGESC 2021, pp..129-141.
21. G Vijayakumar, M Sujith, S Saravanan, Dipesh B Pardeshi, MA Inayathullaa," [An optimized MPPT method for PV system with fast convergence under rapidly changing of irradiation](#)", 2022 International Virtual Conference on Power Engineering Computing and Control: Developments in Electric Vehicles and Energy Sector for Sustainable Future (PECCON), pp.1-4.
22. VM Geetha, S Saravanan, M Swathisriranjani, CS Satheesh, S Saranraj, "[Partial Power Processing Based Bidirectional Converter for Electric Vehicle Fast Charging Stations](#)", Journal of Physics: Conference Series, Vol.2325, Issue.1, pp.012028, 2022.
23. M Santhosh Kumar, G Dineshkumar, S Saravanan, M Swathisriranjani, M Selvakumari, "[Converter Design and Control of Grid Connected Hybrid Renewable Energy System Using Neuro Fuzzy Logic Model](#)", 2022 Second International Conference on Computer Science, Engineering and Applications (ICCSEA), pp.1-6, 2022.
24. C Gnanavel, A Johny Renoald, S Saravanan, K Vanchinathan, P Sathishkhanna, "[An Experimental Investigation of Fuzzy-Based Voltage-Lift Multilevel Inverter Using Solar Photovoltaic Application](#)", Smart Grids and Green Energy Systems, pp.59-74, 2022.
25. V Kumarakrishnan, G Vijayakumar, D Boopathi, K Jagatheesan, S Saravanan, B Anand, "[Optimized PSO technique based PID controller for load frequency control of single area power system](#)", Solid State Technology, Vol.63. Issue.5, pp.7979-7990, 2020.
26. G. Poovarasana, S. Susikumar, S. Naveen, N. Mohananthini, S. Saravanan, "Implementation of IoT Based Poultry Feeder Box", International Journal of Innovative Research In Technology, Vol.6, Issue.2, pp.33-38, 2020.
27. N.Gokulnath, B.Jasim Khan, S.Kumaravel, Dr.A.Senthil Kumar and Dr.S.Saravanan, "Soldier Health and Position Tracking System", International Journal of Innovative Research In Technology, Vol-6 Issues 12, pp.39-45, 2020.
28. P.Navaneetha, R.Ramiya Devi, S.Vennila, P.Manikandan and Dr.S.Saravanan, " IOT Based Crop Protection System against Birds and Wild Animal Attacks", International Journal of Innovative Research In Technology, Vol-6 Issues 11, pp.133-143, 2020.
29. K. Punitha, M. Rajkumar, S. Karthick and Dr. S. Saravanan, " Impact of Solar And Wind Integration on Frequency Control System", International Research Journal of Engineering and Technology, Vol 7 Issue 3, pp.1357-1362,2020.
30. A.Arulkumar, S.Balaji, M.Balakrishnan, G.Dineshkumar and S.Saravanan, "Design And Implementation of Low Cost Automatic Wall Painting Machine" International Journal of Engineering Technology Research & Management, Vol-4 Issues 03, pp.170-176, 2020.
31. V.Periyasamy, S.Surya, K. Vasanth, Dr.G.Vijayakumar and Dr.S.Saravanan, "Design And Implementation of Iot Based Modern Weaving Loom Monitoring System" International Journal of Engineering Technology Research & Management, Vol-4 Issues 04, pp.11-18, 2020.
32. M.Yogheshwaran, D.Praveenkumar, S.Pravin, P.M.Manikandan and Dr.S.Saravanan, "IoT Based Intelligent Traffic Control System" International Journal of Engineering Technology Research & Management, Vol-4 Issues 04, pp.59-63, 2020.
33. R.Pradhap, R.Radhakrishnan, P.Vijayakumar, R.Raja and Dr.S.Saravanan, "Solar Powered Hybrid Charging Station For Electrical Vehicle" International Journal of Engineering Technology Research & Management, Vol-4 Issues 04, pp.19-27, 2020.
34. S.Shenbagavalli, T.Priyadharshini, S.Sowntharya, P.Manikandan and Dr.S.Saravanan, "Design and Implementation of Smart Traffic Controlling System" International Journal of Engineering Technology Research & Management, Vol-4 Issues 04, pp.28-36, 2020.
35. M.Pavithra, S.Pavithra, R.Rama Priya, M.Vaishnavee, M.Ranjitha and S.Saravanan, "Fingerprint Based Medical Information System Using IoT" International Journal of Engineering Technology Research & Management, Vol-4 Issues 04, pp.45-51, 2020.
36. A.Ananthan, A.M.Dhanesh, J.Gowtham, R.Dhinesh, G.Jeevitha and Dr.S.Saravanan, "IoT Based Clean Water Supply" International Journal of Engineering Technology Research & Management, Vol-4 Issues 03, pp.154-162, 2020.
37. R.Anbarsan, A.Arsathparvez, K.S.Arunachalam, M.Swathisriranjani and Dr.S.Saravanan, "Automatic Class Room Light Controlling Using Arduino" International Journal of Engineering Technology Research & Management, Vol-4 Issues 03, pp.192-201, 2020.



38. S.Karthikeyan, A.Krishnaraj, P.Magendran, T.Divya and Dr.S.Saravanan , “The Dairy Data Acquisition System” International Journal of Engineering Technology Research & Management, Vol-4 Issues 03, pp.163-169, 2020.
39. M.Amaran, S.Mannar Mannan, M.Madhu, Dr.R.Sagayaraj and Dr. S.Saravanan, “Design And Implementation of Low Cost Solar Based Meat Cutting Machine” International Journal of Engineering Technology Research & Management, Vol-4 Issues 03, pp.202-208, 2020.
40. N.Harish, R.Jayakumar, P.Kalaiyaran, G.Vijayakumar and S. Saravanan, “IoT Based Smart Home Energy Meter” International Journal of Engineering Technology Research & Management, Vol-4 Issues 03, pp.177-183, 2020.
41. K.Subashchandrabose, G.Moulieshwaran, M.Raghul, V.Dhinesh and S.Saravanan, “Design of Portable Sanitary Napkin Vending Machine”, International Journal of Engineering Technology Research & Management, Vol-4 Issues 03, pp.52-58, 2020.
42. D.Hemalatha, S.Indhumathi, V.Myvizhi and S.Saravanan, “Design and Implementation of Intelligent Controller for Domestic Applications”, International Journal of New Innovations in Engineering and Technology, Vol.22, Issue.3, pp.4-7, 2023.
43. S. Divyasri, E. Indhu, M. P. Keerthana, M. Selvakumari and S. Saravanan, “Gas Cylinder Monitoring System using IoT”, International Journal of New Innovations in Engineering and Technology, Vol.22, Issue.3, pp.67-71, 2023.
44. J.Arul, R.Balaji, S.Jeyamoorthy, M.Manipathra, R.Sundar and S.Saravanan, “IoT based Air Conditioner Control using ESP32”, International Journal of New Innovations in Engineering and Technology, Vol.22, Issue.3, pp.48-52, 2023.
45. Vundel Munireddy, J.Prahathesvaran, C.R.Thirunavukarasu, M.Santhosh Kumar and S.Saravanan, “IoT Based Charge Controller for Direct Fast Charging of Electric Vehicles Using Solar Panel”, International Journal of New Innovations in Engineering and Technology, Vol.22, Issue.3, pp.77-81, 2023.
46. D.Monish Kumaar, K.Akash, S.Aswinkumar, S.Saravanan and R. Sagayaraj, “IoT based Industry Surveillance and Air Pollution Monitoring using Drones”, International Journal of New Innovations in Engineering and Technology, Vol.22, Issue.3, pp.14-18, 2023.
47. T.Silambarasan, R.Surya, J.Pravinkumar, R.Sundar and S Saravanan, “IoT based Monitoring System For Sewage Sweeper”, International Journal of New Innovations in Engineering and Technology, Vol.22, Issue.3, pp.88-93, 2023.
48. R.Aravinthan, Alwin.Augustin, P.Divagaran, S.Saravanan and P.Manikandan, “IoT Based Power Consumption and Monitoring System”, International Journal of New Innovations in Engineering and Technology, Vol.22, Issue.3, pp.43-47, 2023.
49. S.Partheeban, S.Sundaravel, S.Umapathi, R.Sagayaraj and S.Saravanan, “IoT based Safety Helmet for Mining Workers”, International Journal of New Innovations in Engineering and Technology, Vol.22, Issue.3, pp.116-120, 2023.
50. K.Eswaramoorthi, R.Manikandan, R.Balamurugan, C.Ramkumar and S.Saravanan, “Smart Parking System using IoT”, International Journal of New Innovations in Engineering and Technology, Vol.22, Issue.3, pp.53-57, 2023.
51. S.Nirmalraj, C.Pranavan, M.Prem and S.Saravanan, “Smart Trolley With IoT Based Billing System”, International Journal of New Innovations in Engineering and Technology, Vol.22, Issue.3, pp.111-115, 2023.
52. V.Gunasekaran, M.Gowtham , S. Anbubalaji, S.Saravanan and R.Prakash, “Solar based Electric Wheel Chair”, International Journal of New Innovations in Engineering and Technology, Vol.22, Issue.3, pp.8-13, 2023.
53. P Thava Prakash, P.Venketesan, D.Vignesh, S.Prakash, S.Saravanan, “Design of Low Cost E-Bicycle using Brushless DC Motor with Speed Regulator”, International Journal of New Innovations in Engineering and Technology, Vol.22, Issue.3, pp.148-153, 2023.
54. D.Tamilarasan, V.S.Vairamuthu, Y.Vasanth, K.Umadevi, S.Saravanan, “GSM based Agricultural Motor Control”, International Journal of New Innovations in Engineering and Technology, Vol.22, Issue.3, pp.172-177, 2023.
55. P. Vimal, S.Veerasingamani, R.Srihari, C.S.Satheesh, S.Saravanan, “IoT Based Optimal Power Management System For Smart Grid”, International Journal of New Innovations in Engineering and Technology, Vol.22, Issue.3, pp.160-165, 2023.
56. S.Abimanyu, P.Jagadheeswaran, S.Jaganath, K.Sanjay, R.Sivapranesh, K.Velmurugan, N.Mohananthini, C.S.Satheesh, S.Saravanan, “Portable Solar Tree”, International Journal of New Innovations in Engineering and Technology, Vol.22, Issue.3, pp.154-159, 2023.
57. M.Karthikeyan, S.Bilalahamad, V.A.Chandru, V.Deepika and S.Saravanan, “Design and Development of IoT based Motor Starter”, International Journal of New Innovations in Engineering and Technology, Vol.22, Issue.3, pp.178-183, 2023.
58. R.Anbarsan, A.Arsathparvez, K.S.Arunachalam, M.Swathisriranjani and S.Saravanan, “Automatic Class Room Light Controlling Using Arduino” International Journal of Engineering Technology Research & Management (IJETRM), Vol-4 Issues 03, pp.192-201, 2020.



59. S.Karthikeyan, A.Krishnaraj, P.Magendran, T.Divya and S.Saravanan, "The Dairy Data Acquisition System" International Journal of Engineering Technology Research & Management (IJETRM), Vol-4 Issues 03, pp.163-169, 2020.
60. N.Harish, R.Jayakumar, P.Kalaiyaran, G.Vijayakumar and S. Saravanan, "IoT Based Smart Home Energy Meter" International Journal of Engineering Technology Research & Management (IJETRM), Vol-4 Issues 03, pp.177-183, 2020.
61. G. Poovarasan, S. Susikumar, S. Naveen, N. Mohananthini, S. Saravanan," Study of Poultry Fodder Passing Through Trolley in Feeder Box," International Journal of Engineering Technology Research & Management, vol.4, Issue.1, pp.76-83, 2020.
62. A.Ananthan, A.M.Dhanesh, J.Gowtham, R.Dhinesh, G.Jeevitha and S.Saravanan, "IoT Based Clean Water Supply" International Journal of Engineering Technology Research & Management (IJETRM), Vol-4 Issues 03, pp.154-162, 2020.
63. Ram Kumar C, Saravanan S, and Nagarajan C, "Hybrid LSTM and Deep Reinforcement Learning for Autonomous Battery Health Optimization in Electric Vehicles", Electrical Power Systems Research, Vol-253 Issues 112535, ISSN No:0378-7796,2025.
64. Gopinathan, V. R. (2024). Real-Time Fault-Tolerant Multi-Cloud Database Architectures for High Availability Applications. International Journal of Future Innovative Science and Technology (IJFIST), 7(4), 13148.
65. Chandra, S., Rengarajan, A., Sahoo, G. S., & Sharma, S. (2023, December). Identifying Neuronal Damage and Plasticity by Analyzing Changes in Diffusion Tensor Imaging. In International Conference on Data Science, Machine Learning and Applications (pp. 433-438). Singapore: Springer Nature Singapore.
66. Sugumar, R. (2025). Federated AI in Offline-First Mobile Health Architectures for Privacy-Preserving Clinical Intelligence. International Journal of Science, Research and Technology, 8(4), 14589-14600.
67. Murugeswari, B., Rajalakshmi, S., & Sudharson, K. (2023). Hybrid Approach for Privacy Enhancement in Data Mining Using Arbitrariness and Perturbation. Computer Systems Science & Engineering, 44(3).
68. Pandey, V. K., Mishra, S., Rengarajan, A., Savita, & Roomi, M. M. (2024, March). Enhancing Weather Forecasting with Machine Learning Techniques. In International Conference on Renewable Power (pp. 147-156). Singapore: Springer Nature Singapore.
69. Soundappan, S. J. (2025). Next Generation AI Enabled Holistic Cognitive Platform for Secure Cloud Network Intelligence Enterprise Systems and Digital Trust Optimization. International Journal of Computer Technology and Electronics Communication, 8(5), 11534-11542.
70. Mathew, A. (2022). Leveraging Big Data Analytics to Power AI and ML (Machine Learning) Automation. Educational Research (IJMERC), 4(5), 131-134.
71. Sugumar, R. (2024). AI-Augmented Quality Engineering for Performance Optimization and Test Orchestration in Distributed Systems. International Journal of Science, Research and Technology, 7(5), 12835-12846.
72. Akila, R. (2024). A deep reinforcement learning approach for optimizing inventory management in the agri-food supply chain. J. Electrical Systems, 20(4s), 2238-2247.
73. Mahendran, M., Anbazhagan, K., Pavithran, G., Nivas, A., & Pandey, S. D. (2022). Earthquake Damage Prediction using Machine Learning. Grenze International Journal of Engineering & Technology (GIJET), 8(1).
74. Gopinathan, V. R. (2025). Enterprise AI Frameworks for Financial Data Engineering Behavioural Analytics and Intelligent Cloud Solutions. International Journal of Research Publications in Engineering, Technology and Management (IRPETM), 8(4), 12499-12506.
75. Kondalsamy, P., & Kaliappan, K. (2025). An Optimal Prediction of Leaf Disease Based on Hybrid Deep Learnings and Metaheuristic Technique. Traitement du Signal, 42(1), 363.
76. Deivendran, P., Babu, P. S., Malathi, G., Anbazhagan, K., & Kumar, R. S. (2023). Emotion Recognition for Challenged People Facial Appearance in Social using Neural Network. arXiv preprint arXiv:2305.06842.
77. Sugumar, R. (2025). Unified AI Framework for Predictive Data Engineering and Real Time Prescription and Billing Systems. International Journal of Advanced Engineering Science and Information Technology (IJAESIT), 8(5), 17261.
78. Vekariya, V., Kumar, S., & Rengarajan, A. (2024). A distinctive and smart agricultural knowledge-based framework using ontology. In Sustainability in Digital Transformation Era: Driving Innovative & Growth (pp. 207-213). CRC Press.
79. Gopinathan, V. R. (2025). Software engineering practices for AI-driven systems: From development to deployment (MLOps perspective). International Journal of Science, Research and Technology, 8(1), 13493-13500.
80. Mathew, A. R. (2022). Threats and protection on E-sim: a prospective study. Novel Perspectives of Engineering Research, 8, 76-81.



81. Naveena, S., & Kavitha, K. (2025). Gossypium herbaceum: Folium disease identification and classification using Efficient Net-Coordinate Convolutional Neural Network (EcoNet). *Engineering Applications of Artificial Intelligence*, 152, 110701.
82. Rengarajan, A., Mishra, A., Kulhar, K. S., Shrivastava, V. P., & Alawneh, Y. J. J. (2024, March). Role of Deep Reinforcement Learning in Mitigating Cyber Security Issues: A Review. In *International Conference on Renewable Power* (pp. 37-48). Singapore: Springer Nature Singapore.
83. Achari, A. P. S. K., & Sugumar, R. (2024, November). Performance analysis and determination of accuracy using machine learning techniques for naive bayes and random forest. In *AIP Conference Proceedings* (Vol. 3193, No. 1, p. 020199). AIP Publishing LLC.
84. Mathew, A., & Alex, H. (2022). Detect & protect-medical device cybersecurity. *Curr. Overview Sci. Technol. Res*, 1, 60-68.
85. Sammy, F., Chettier, T., Boyina, V., Shingne, H., Saluja, K., Mali, M., ... & Shobana, A. (2025). Deep Learning-Driven Visual Analytics Framework for Next-Generation Environmental Monitoring. *Journal of Applied Science and Technology Trends*, 114-122.
86. Anbazhagan, K. (2024). Trustworthy and Adaptive AI Systems for Enterprise Analytics Cybersecurity and Decision Optimization Using API-First and Cloud-Native Architectures. *International Journal of Technology, Management and Humanities*, 10(03), 65-74.
87. Mathew, A. (2021). Deep reinforcement learning for cybersecurity applications. *Int J Comput Sci Mob Compu*, 10(12), 32-38.
88. Dhinakaran, D. (2022). Joe Prathap P. M, Selvaraj D, Arul Kumar D and Murugeswari B, " Mining Privacy-Preserving Association Rules based on Parallel Processing in Cloud Computing." *International Journal of Engineering Trends and Technology*, 70(3), 284-294.
89. Karthika, K., Anusha, K., Kavitha, K., Harshadha, R., Dharshini, D. S., & Sundhar, N. A. (2025, April). Frequency Reconfigurable Antenna using Advanced Materials: A Study. In *2025 3rd International Conference on Advancements in Electrical, Electronics, Communication, Computing and Automation (ICAECA)* (pp. 1-6). IEEE.
90. Thavamani, C., & Rengarajan, A. (2024). Clustering related behaviour of users by the use of partitioning and parallel transaction reduction algorithm. *International Journal of Advanced Intelligence Paradigms*, 29(2-3), 122-132.
91. Sugumar, R. (2025). Unified AI Framework for Predictive Data Engineering and Real Time Prescription and Billing Systems. *International Journal of Advanced Engineering Science and Information Technology (IJAESIT)*, 8(5), 17261.
92. Soundappan, S. J., & Sugumar, R. (2016). Optimal knowledge extraction technique based on hybridisation of improved artificial bee colony algorithm and cuckoo search algorithm. *International Journal of Business Intelligence and Data Mining*, 11(4), 338-356.
93. SakthiPreetha, A., Kavitha, K., Karthika, K., & Manohari, R. G. (2025, April). A Novel Metasurface-Embedded Antenna for WBAN Communications. In *2025 3rd International Conference on Advancements in Electrical, Electronics, Communication, Computing and Automation (ICAECA)* (pp. 1-4). IEEE.
94. Murugeswari, B., Selvaraj, D., Sudharson, K., & Radhika, S. (2023). Data Mining with Privacy Protection Using Precise Elliptical Curve Cryptography. *Intelligent Automation & Soft Computing*, 35(1).
95. Gopinathan, V. R. (2025). Software engineering practices for AI-driven systems: From development to deployment (MLOps perspective). *International Journal of Science, Research and Technology*, 8(1), 13493-13500.
96. Anbazhagan, K., Kumar, R., Thilagavathy, R., & Anuradha, D. (2024, March). Shortest Job First with Gateway-based Resource Management Strategy for Fog Enabled Cloud Computing. In *2024 4th International Conference on Data Engineering and Communication Systems (ICDECS)* (pp. 1-6). IEEE.
97. Kannadhasan, S., Vasuki, S., Kavitha, K., Karthikeyan, P., & Usha, S. G. A. (Eds.). (2025, April). Preface: Role of Artificial Intelligence and IoT in Engineering, Technology & Science [ICRAETS 2024]. In *AIP Conference Proceedings* (Vol. 3258, No. 1, p. 010001). AIP Publishing LLC.
98. Dhinakaran, D., Prathap, P. J., Selvaraj, D., Kumar, D. A., & Murugeswari, B. (2022). Mining privacy-preserving association rules based on parallel processing in cloud computing. *International Journal of Engineering Trends and Technology*, 70(3), 284-294.