



Solar Operated Grass Cutting Machine

P.Sampathkumar, S.Gobika, T.Manimala, K.Rubasri

Department of Agricultural Engineering, Muthayammal Engineering College, Namakkal, Tamil Nadu, India

Publication History: Received: 25.02.2026; Revised: 20.03.2026; Accepted: 25.03.2026; Published: 28.03.2026.

ABSTRACT: Grass cutting is an essential maintenance activity carried out in gardens, lawns, parks, playgrounds, and agricultural fields to maintain cleanliness, appearance, and healthy plant growth. This project presents the design and development of a solar operated grass cutting machine controlled through Android Bluetooth technology. The system aims to reduce human effort, minimize fuel consumption, and promote the use of renewable energy in lawn maintenance. The machine is powered by solar energy, which is stored in a rechargeable battery through a solar panel. An Android smartphone application is used to control the machine wirelessly via a Bluetooth module. A microcontroller acts as the central unit that receives commands from the Bluetooth module and controls the motors accordingly.

KEYWORDS: Solar energy, Grass cutting machine, Arduino Uno, Bluetooth control, DC motor, Renewable energy, Automation

I. INTRODUCTION

The increasing shift toward automation and smart technologies has transformed traditional mechanical systems into intelligent and energy-efficient devices. Lawn maintenance, which was once a completely manual and labor-intensive task, is now being enhanced through the integration of renewable energy and wireless communication systems. With global solar adoption rising in countries such as India, Germany, and the United States, renewable energy technologies are becoming more affordable and accessible. This growing accessibility makes the development of small-scale solar-powered devices both practical and economically viable.

II. WORKING PRINCIPLE

2.1 General

Bluetooth control grass cutter consists of a motor, gear arrangement of a cutting tool. For this system the power gets from the solar panel with a respective battery. By using the Bluetooth module, forward and reverse direction can be controlled. Forward and reverse program already prewritten in the microcontroller.

From the PIC controller it is fed from the relay if any fault occurs in the electronic switches it will rectify by using a relay operation in it. Finally the dc shunt motor is connected to the cutting tool and it starts working. A Bluetooth module HC-05 Bluetooth Module is connected to the Arduino.

How it works:

1. The user installs a mobile app (e.g., Serial Bluetooth Terminal).
2. The phone connects to the Bluetooth module.
3. User sends commands (like *1,*2,*3,*4,*5,*6,*7).

2.2 Signal Processing

- The Bluetooth module sends received data to Arduino via serial communication.
- Arduino processes the command and gives output signals to:

Motor

Relay module etc.,

III. COMPONENTS

The solar operated motorized grass cutter consists of the following components to fulfill the requirements of complete operation of the machine.

1. Arduino Uno
2. Solar Panel

3. Bluetooth
4. Dc Motor
5. Relay
6. Tires
7. Battery
8. LCD display
9. Power supply board

IV. BLOCK DIAGRAM

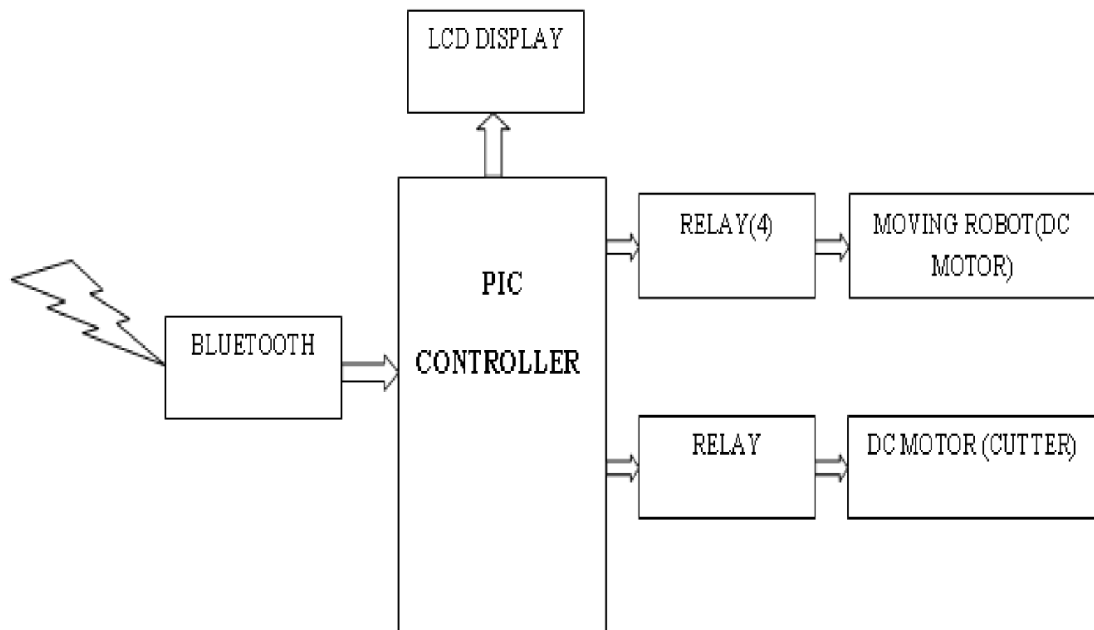

SCHEMATIC REPRESENTATION

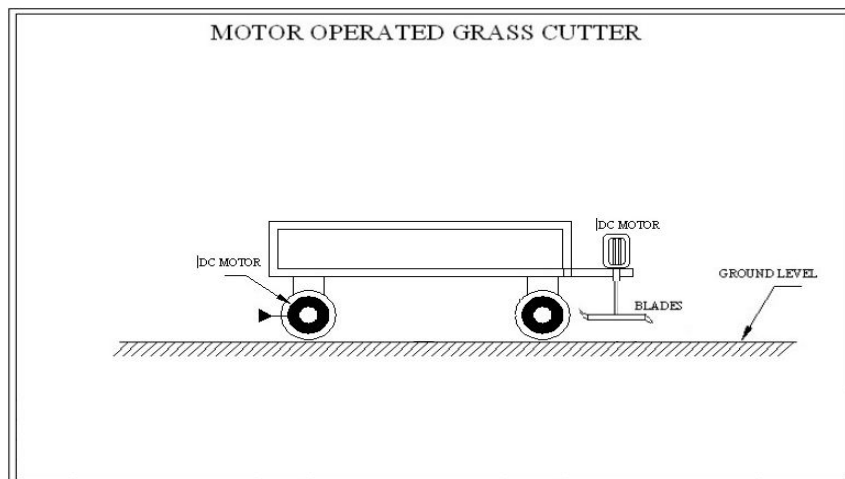

4.1 ARDUINO UNO:

- Arduino is a single-board microcontroller to make using electronics in multidisciplinary projects more accessible.
- The hardware consists of an open-source hardware board designed around an 8-bit Atmel AVR microcontroller, or a 32-bit Atmel ARM.
- The software consists of a standard programming language compiler and a boot loader that executes on the microcontroller.

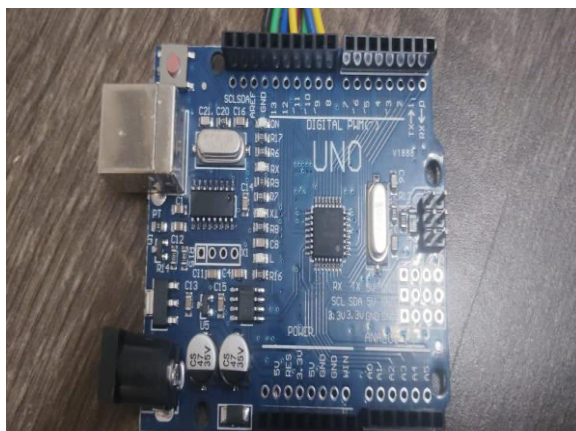

4.2 SOLAR PANEL:



- A solar panel (photovoltaic module or photovoltaic panel) is a packaged interconnected assembly of solar cells, also known as photovoltaic cells.
- The solar panel is used as a component in a larger photovoltaic system to offer electricity for commercial and residential applications.

4.3 HC-05 BLUETOOTH:

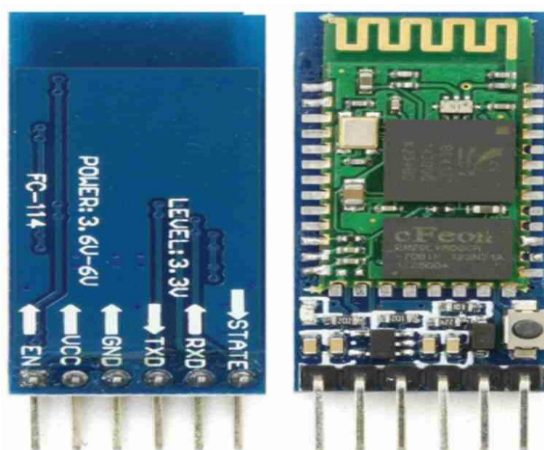

The HC-05 is a class 2 Bluetooth module designed for transparent wireless serial communication. It is pre-configured as a slave bluetooth device.

V. PROJECT ASSEMBLING

5.1 FRAME PREPARATION AND WHEEL MOUNTING :

The frame is the main supporting structure that holds the solar panel, battery, motor, wheels, and cutting blade assembly.

Insert shaft through wheel hub for joining of tyres.



5.2 MOUNTING COMPONENTS ON THE FRAME:

Motor unit:

There are two types of motors used,

- Cutting motor (for blade)
- Wheel motor (for movement)

Control unit:

Arduino Uno Arduino is the main controller. It receives programmed instructions. It controls the relay and updates the LCD.



Display unit:

The LCD is connected to Arduino digital pins.

Switching unit:

- ❖ Relay module Relay is connected between Arduino and Motor.
- ❖ Arduino gives 5V signal to relay.
- ❖ Relay switches 12V supply to motor.

5.3 BLADE AND MOTOR JOINING:



A DC motor is mounted at the bottom of the machine frame and fixed firmly using bolts and nuts to avoid vibration. The motor shaft is used to rotate the blade, the cutting blade is attached to the motor shaft. The blade is mounted at the center of the shaft.

5.4 SOLAR PANEL MOUNTING



The solar panel is placed on the wooden base plate and fixed using metal bolts, nuts. These fasteners will hold the panel firmly.

The panel is mounted at a slightly inclined angle (~ 30- 40 degree) rather than flat.

5.5 BLUETOOTH CONTROL:

Bluetooth control is a wireless communication technology used to control electronic devices over a short distance using radio waves.

The process is:

- A smartphone or controller sends a command through Bluetooth.
- The Bluetooth module (HC 05) in the device receives the signal.
- The microcontroller processes the command.
- The connected components such as motors, relays, or LEDs perform the required action.

VI. FACTORS DETERMINING THE CHOICE OF MATERIALS

The material selected must possess the necessary properties for the proposed application.

The following four types of principle properties of materials decisively affect their selection

a. Physical



- b. Mechanical
- c. From manufacturing point of view
- d. Chemical

The various physical properties concerned are melting point, thermal conductivity, specific heat, coefficient of thermal expansion, specific gravity, electrical conductivity, magnetic purposes etc. The various Mechanical properties concerned are strength in tensile, compressive shear, bending, torsional and buckling load, fatigue resistance, impact resistance, elastic limit, endurance limit, and modulus of elasticity, hardness, wear resistance and sliding properties.

VII. CONCLUSION

In this proposed scheme made with pre planning, it is an economical method compared to the existing method. It provides flexibility to the user. The comparative gain that can be accomplished is the utilization of the motor in the control unit. The solar-powered grass cutter project demonstrates an innovative and eco-friendly approach to lawn maintenance by utilizing renewable energy. This system uses solar panels to convert sunlight into electrical energy, which is stored in a battery and used to drive the motors for cutting and movement. By eliminating the need for fuel or external electricity, the project reduces environmental pollution and operating costs. The integration of components such as DC motors, a control unit, and a cutting mechanism ensures efficient performance and ease of use. This project is especially beneficial for small gardens and agricultural applications where sustainable solutions are needed. Additionally, it requires less maintenance compared to conventional grass cutters and provides a safer alternative for users. The design can be further improved by incorporating automation technologies like sensors and Bluetooth control for remote operation.

REFERENCES

1. Manpreet Singh, Ashutosh Padhan, Suman Saurabh, Kumar Priyesh, Mausham Rai and Takkellapati Naveen, "A Review and Comparative Analysis of Solar, Electric and Gasoline Lawnmowers: An Extensive Study", IJISSET - International Journal of Innovative Science, Engineering & Technology, Vol. 3 Issue 4, ISSN 2348 – 7968, April 2016.
2. K. Naresh, M. Yashwanth Kumar, R. Prashanth, M. Venkata Ramana Reddy, "Design and Fabrication of Solar Grass Cutter", ISSN (Online) 2581-9429, International Journal of Advanced Research in Science, Communication and Technology (IJARSCT), Volume 3, Issue 1, November 2023.
3. Kartik R. Khodke, Himanshu Kukreja, Sumitkotekar, Nital Kukade, C.J. Shende, "Literature Review of Grass Cutter Machine", International Journal of Emerging Technologies in Engineering Research (IJETER), Volume 6, Issue 2, February (2018).
4. Mohammed Afan Ashraf, Muzzammil Hussain, Mohammed Muzaffar, Abdullah, "Grass Cutter Machine", International Journal of Scientific Research & Engineering Trends Volume 6, Issue 2, Mar-Apr-2020, ISSN (Online): 2395-566X.
5. Akshay Ramteke, Yogesh Bokde, Amit Waghmare, Ajay Kumar Nagpure, Nitinkumar Padghan, "A Review on Design and Modification of Grass Cutting Machine (Cylinder Lawn Mover)", JETIR May 2020, Volume 7, Issue 5 www.jetir.org (ISSN-2349-5162).
6. Ramya P, Shailendra Kumar, Yogesh Sharma, Hitesh Ritolia, Kondeti Veerendra, "A Fully Automated Lawn Cutter Using Solar Panel", International Journal of Science and Research (IJSR) ISSN:2319-7064, Research Gate Impact Factor (2018): 0.28 | SJIF (2019): 7.583.
7. Saurabh Kumar Kulhariya, Dr. Anurag Singh Tomer, Kavita Krishan, Narendra Kumar Yadav and Ritesh Kumar Mishra, "Performance evaluation of solar operated bidirectional grass cutter", Journal of Pharmacognosy and Phytochemistry 2020; 9(3): 329-334, E-ISSN: 2278-4136, P-ISSN: 2349-8234.
8. R. M. Asif, J. Arshad, M. Shakir, S. M. Noman, and A. U. Rehman, "Energy efficiency augmentation in massive MIMO systems through linear precoding schemes and power consumption modeling," Wireless Communications and Mobile Computing, vol. 2020, Article ID 8839088, pp. 1–13, 2020.
9. C. Nagarajan and M. Madheswaran - 'Stability Analysis of Series Parallel Resonant Converter with Fuzzy Logic Controller Using State Space Techniques' - Taylor & Francis, Electric Power Components and Systems, Vol.39 (8), pp.780-793, May 2011. DOI: 10.1080/15325008.2010.541746
10. C. Nagarajan and M. Madheswaran - 'Experimental verification and stability state space analysis of CLL-T Series Parallel Resonant Converter' - Journal of Electrical Engineering, Vol.63 (6), pp.365-372, Dec.2012. DOI: 10.2478/v10187-012-0054-2



11. C.Nagarajan and M.Madheswaran - 'Performance Analysis of LCL-T Resonant Converter with Fuzzy/PID Using State Space Analysis'- Springer, Electrical Engineering, Vol.93 (3), pp.167-178, September 2011. DOI 10.1007/s00202-011-0203-9
12. S.Tamilselvi, R.Prakash, C.Nagarajan, "Solar System Integrated Smart Grid Utilizing Hybrid Coot-Genetic Algorithm Optimized ANN Controller" Iranian Journal Of Science And Technology-Transactions Of Electrical Engineering, DOI10.1007/s40998-025-00917-z,2025
13. S.Tamilselvi, R.Prakash, C.Nagarajan, " Adaptive sliding mode control of multilevel grid-connected inverters using reinforcement learning for enhanced LVRT performance" Electric Power Systems Research 253 (2026) 112428, doi.org/10.1016/j.epr.2025.112428
14. S.Thirunavukkarasu, C. Nagarajan, 2024, "Performance Investigation on OCF and SCF study in BLDC machine using FTANN Controller," Journal of Electrical Engineering And Technology, Volume 20, pages 2675–2688, (2025), doi.org/10.1007/s42835-024-02126-w
15. C. Nagarajan, M.Madheswaran and D.Ramasubramanian- 'Development of DSP based Robust Control Method for General Resonant Converter Topologies using Transfer Function Model'- ActaElectrotechnica et Informatica Journal , Vol.13 (2), pp.18-31, April-June.2013, DOI: 10.2478/aei-2013-0025.
16. C.Nagarajan and M.Madheswaran - 'DSP Based Fuzzy Controller for Series Parallel Resonant converter'- Springer, Frontiers of Electrical and Electronic Engineering, Vol. 7(4), pp. 438-446, Dec.12. DOI 10.1007/s11460-012-0212-0.
17. C.Nagarajan and M.Madheswaran - 'Experimental Study and steady state stability analysis of CLL-T Series Parallel Resonant Converter with Fuzzy controller using State Space Analysis'- Iranian Journal of Electrical & Electronic Engineering, Vol.8 (3), pp.259-267, September 2012.
18. C.Nagarajan and M.Madheswaran, "Analysis and Simulation of LCL Series Resonant Full Bridge Converter Using PWM Technique with Load Independent Operation" has been presented in ICTES'08, a IEEE / IET International Conference organized by M.G.R.University, Chennai.Vol.no.1, pp.190-195, Dec.2007
19. SuganthiMullainathan, Ramesh Natarajan, "An SPSS and CNN modelling based quality assessment using ceramic materials and membrane filtration techniques", RevistaMateria (Rio J.) Vol. 30, 2025, DOI: <https://doi.org/10.1590/1517-7076-RMAT-2024-0721>
20. M Suganthi, N Ramesh, "Treatment of water using natural zeolite as membrane filter", Journal of Environmental Protection and Ecology, Volume 23, Issue 2, pp: 520-530,2022
21. M. Boxwell, Solar Electricity Handbook, 2012 ed. Green Stream Publishing, 2012. ISBN: 978-1-907670-22-0.(ebook)
22. G. N. Tiwari and R. K. Mishra, Advanced Renewable Energy Sources. Cambridge, U.K.: RSC Publishing, Nov. 2011. ISBN: 978-1-84973-380-9.(ebook)
23. S. P. Sukhatme, Solar Energy: Principles of Thermal Collection and Storage. New Delhi, India: Tata McGraw-Hill, 2008.(ebook)
24. M. Schwartz, Internet of Things with Arduino. Birmingham, UK: Packt Publishing, 2016.(ebook)
25. <https://youtu.be/X0OZ6tpZ3Mc?si=fQg2Q3sRwja2UV8E>
26. https://youtu.be/yN2GlqtbXGQ?si=_N6pgmShvJMu6lry
27. <https://youtu.be/ZiS8w-141Wc?si=-hxWExvGtc37kt0C>
28. Anand, L., Maurya, M., Seetha, J., Nagaraju, D., Ravuri, A., & Vidhya, R. G. (2023, July). An intelligent approach to segment the liver cancer using Machine Learning Method. In 2023 4th international conference on electronics and sustainable communication systems (ICESC) (pp. 1488-1493). IEEE.
29. Rajendran, S., Sundarapandi, A. M. S., Krishnamurthy, A., & Thanarajan, T. (2022). An intelligent face recognition technology for iot-based smart city application using condition-cnn with foraging learning pso model. International Journal of Pattern Recognition and Artificial Intelligence, 36(14), 2256018.
30. Murugeswari, B., & Sujatha, R. (2014). Preservation of Privacy for Multiparty Computation System with Homomorphic Encryption. International Journal of Emerging Technology and Advanced Engineering, 4(3), 530-535.
31. Sugumar, R. (2025). Unified AI Framework for Predictive Data Engineering and Real Time Prescription and Billing Systems. International Journal of Advanced Engineering Science and Information Technology (IJAESIT), 8(5), 17261.
32. Samrat, B., Thomas, P. K., Kumar, S., Benila, A., Bhardwaj, R., & Vigenesh, M. (2024, December). Industrial informatics in optimizing software-defined vehicles for logistics. In 2024 IEEE 2nd International Conference on Innovations in High Speed Communication and Signal Processing (IHCSPP) (pp. 1-9). IEEE.
33. Soundappan, S. J. (2024). AI-driven customer intelligence in enterprise lakehouse systems Sentiment Mining Governance-Aware Analytics and Real-Time Data Synchronization. International Journal of Advanced Engineering Science and Information Technology.
34. Rajasekar, M. (2024). AI-Powered Cyber-Secure Federated Learning on AWS for Next-Generation Digital Banking Analytics. International Journal of Advanced Research in Computer Science & Technology (IJARCST), 7(3).



35. Deivendran, P., Babu, P. S., Malathi, G., Anbazhagan, K., & Kumar, R. S. (2023). Emotion Recognition for Challenged People Facial Appearance in Social using Neural Network. arXiv preprint arXiv:2305.06842.
36. Sugumar, R., & Murugeswari, B. (2016). An Efficient MChord based Authentication for Vehicular Ad-Hoc Networks.
37. Pandey, V. K., Mishra, S., Rengarajan, A., Savita, & Roomi, M. M. (2024, March). Enhancing Weather Forecasting with Machine Learning Techniques. In International Conference on Renewable Power (pp. 147-156). Singapore: Springer Nature Singapore.
38. Mathew, A., & Alex, H. (2025). Federated Learning for Secure Genomic Research: Privacy-Preserving AI Solutions for Precision Medicine. *Science and Technology: Developments and Applications* Vol. 9, 36-43.
39. Selvi, G. V., Anbarasan, A. B., Murthy, B. A., & Prabavathy, S. (2023). An Application Oriented Integrated Unequal Clustering Algorithm for Wireless Sensor Network. In Underwater Vehicle Control and Communication Systems Based on Machine Learning Techniques (pp. 140-154). CRC Press.
40. Soundappan, S. J. (2025). Next Generation AI Enabled Holistic Cognitive Platform for Secure Cloud Network Intelligence Enterprise Systems and Digital Trust Optimization. *International Journal of Computer Technology and Electronics Communication*, 8(5), 11534-11542.
41. Rajasekar, M. (2024). Real-Time Predictive DevOps Intelligence for Risk-Aware Digital Business Processes in Cloud and SAP Ecosystems. *International Journal of Advanced Research in Computer Science & Technology (IJARCST)*, 7(4), 10713-10718.
42. Jagadeesh, S., & Sugumar, R. (2017). A comparative study on artificial bee colony with modified ABC algorithm. *European Journal of Applied Sciences*, 9(5), 243-248.
43. Murugeswari, B., Sarukesi, K., & Jayakumar, C. (2010, March). An efficient method for knowledge hiding through database extension. In 2010 International Conference on Recent Trends in Information, Telecommunication and Computing (pp. 342-344). IEEE.
44. Reddy, K. V. V. K., & Vimal, V. R. (2024, July). A novel approach on improved segmentation and classification of remote sensing images using AlexNet compared over linear discriminant analysis with improved accuracy. In 2024 Second International Conference on Advances in Information Technology (ICAIT) (Vol. 1, pp. 1-6). IEEE.
45. Gowthami, D., & Vigenesh, M. (2024). Distributed and Lightweight Intrusion Detection for IoT: A Lightweight Pyramidal U-Net With Tri-Level Dual Inception-Based Framework. In *The Convergence of Self-Sustaining Systems With AI and IoT* (pp. 154-173). IGI Global Scientific Publishing.
46. Anand, P. V., & Anand, L. (2023, December). An Enhanced Breast Cancer Diagnosis using RESNET50. In 2023 International Conference on Innovative Computing, Intelligent Communication and Smart Electrical Systems (ICSSES) (pp. 1-5). IEEE.
47. Mathew, A. (2022). Leveraging Big Data Analytics to Power AI and ML (Machine Learning) Automation. *Educational Research (IJMCR)*, 4(5), 131-134.
48. Dhinakaran, D. (2022). Joe Prathap P. M, Selvaraj D, Arul Kumar D and Murugeswari B, " Mining Privacy-Preserving Association Rules based on Parallel Processing in Cloud Computing." *International Journal of Engineering Trends and Technology*, 70(3), 284-294.
49. Poornima, G., & Anand, L. (2024, April). Effective Machine Learning Methods for the Detection of Pulmonary Carcinoma. In 2024 Ninth International Conference on Science Technology Engineering and Mathematics (ICONSTEM) (pp. 1-7). IEEE.
50. Rengarajan, A., Jayakumar, C., & Sugumar, R. (2012). Optimization Of Recent Attacks Using Internet Protocol. *National Journal of System and Information Technology*, 5(1), 8.
51. Mathew, A., & Romasco, L. (2024). Forensic Investigation of Artificial Intelligence Systems. *Research Updates in Mathematics and Computer Science* Vol. 4, 154-164.
52. Vekariya, V., Kumar, S., & Rengarajan, A. (2024). A distinctive and smart agricultural knowledge-based framework using ontology. In *Sustainability in Digital Transformation Era: Driving Innovative & Growth* (pp. 207-213). CRC Press.
53. Soundappan, S. J. (2020). Big data analytics in healthcare: Applications for pandemic forecasting. *International Journal of Advanced Research in Computer Science & Technology*, 3.
54. Sugumar, R. (2024). AI-Augmented Quality Engineering for Performance Optimization and Test Orchestration in Distributed Systems. *International Journal of Science, Research and Technology*, 7(5), 12835-12846.
55. Soundappan, S. J., & Sugumar, R. (2016). Optimal knowledge extraction technique based on hybridisation of improved artificial bee colony algorithm and cuckoo search algorithm. *International Journal of Business Intelligence and Data Mining*, 11(4), 338-356.
56. Mathew, A. (2025). Ahead of the breach: Predictive threat intelligence in aviation inspired by Scattered Spider attacks. *Multidisciplinary International Journal of Research and Development (MIJRD)*, 4(6), 54-58.



57. Soundappan, S. J. (2021). DataOps: Orchestrating Reliable ML Data Pipelines. *International Journal of Research and Applied Innovations*, 4(4), 5533-5537.
58. Garg, V. K., Soundappan, S. J., &Kaur, E. M. (2020). Enhancement in intrusion detection system for WLAN using genetic algorithms. *South Asian Research Journal of Engineering and Technology*, 2(6), 62–64.
59. Anand, L., Tyagi, R., & Mehta, V. (2024, January). Food recognition using deep learning for recipe and restaurant recommendation. In *Proceedings of Eighth International Conference on Information System Design and Intelligent Applications* (pp. 269-279). Singapore: Springer Nature Singapore.
60. Kumar, A., &Anand, L. (2025). A Novel EEG-Based Deep Learning Framework for Enhancing Communication in Locked-In Syndrome Using P300 Speller and Attention Mechanisms. *KSII Transactions on Internet and Information Systems (TIIS)*, 19(11), 3841-3855.
61. Soundappan, S. J. (2022). AI-Based Fault Detection and Isolation for Reliability in Modern Power Systems. *International Journal of Research Publications in Engineering, Technology and Management (IJRPETM)*, 5(4), 7106-7110.
62. Chandra, S., Rengarajan, A., Sahoo, G. S., & Sharma⁴, S. (2024, October). Identifying Neuronal Damage and Plasticity by Analyzing Changes in Diffusion Tensor. In *Proceedings of the 5th International Conference on Data Science, Machine Learning and Applications; Volume 2: ICDSMLA 2023, 15–16 December, Hyderabad, India (Vol. 2, p. 433)*. Springer Nature.